

End Carriage, Geared Motor, Peripheral Equipment

KITO CRANE

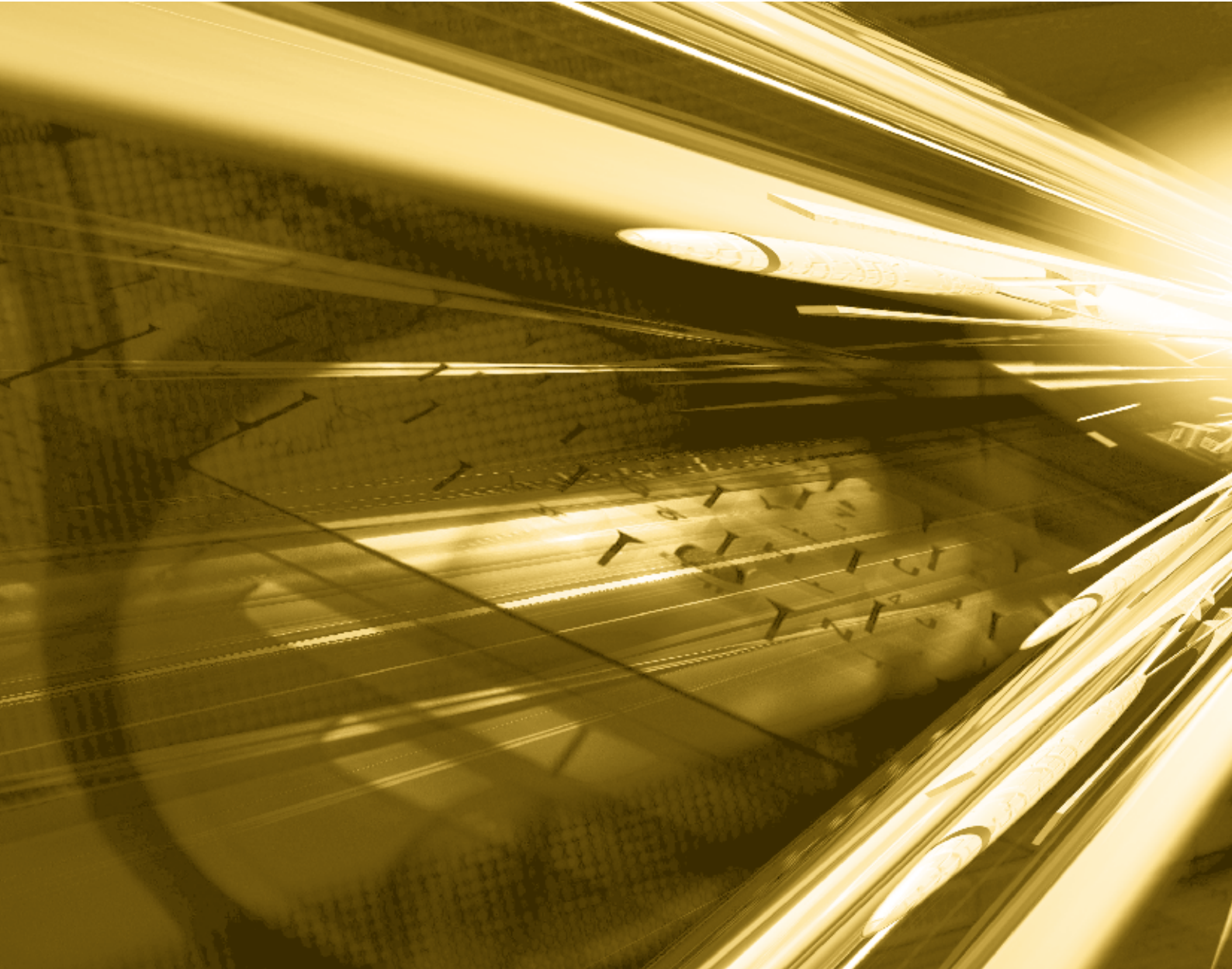

Giving top priority to the every industrial workplace-KITO CRANES.



Cranes are widely used in the workplace to improve work efficiency, to use limited space effectively and to help reduce costs. To meet the diversifying demands of the industrial world, KITO manufactures all kinds of cranes from simple manual cranes to motorized cranes with a single or double girder. All of our products have been designed and built taking into consideration safety, operability and durability. In addition, we have the cranes which are quiet and vibrate less and which are suitable for a working environment where quiet operation is important.



Table of CONTENTS

KITO Crane Applications	4
Crane Outline	11
End Carriage Capacity	14
Features of End Carriages	15
Geared Motor Capacity	16
Features of Geared Motors	17
End Carriage Specifications	18
Geared Motor Specifications	26
Crane peripheral Equipment Installation Outline	28
Control Boxes	30
SOFTRUN Device	32
Power Supply Cables and Accessories	33
Cable Hangers	34
Crane Girder Allowable Span	35
Peripheral Equipment Coverage	36

Note: All measurements used in this catalogue are metric (SI unit system)

KITO

CRANE TEST EQUIPMENT

At KITO, cranes are tested for durability and reliability using special equipment.



Test equipment capacity at KITO factory

Traveling crane	Hoist
Max. test load 50 t	Max. test load 100 t
Span 30 m	

[Overhead cranes]

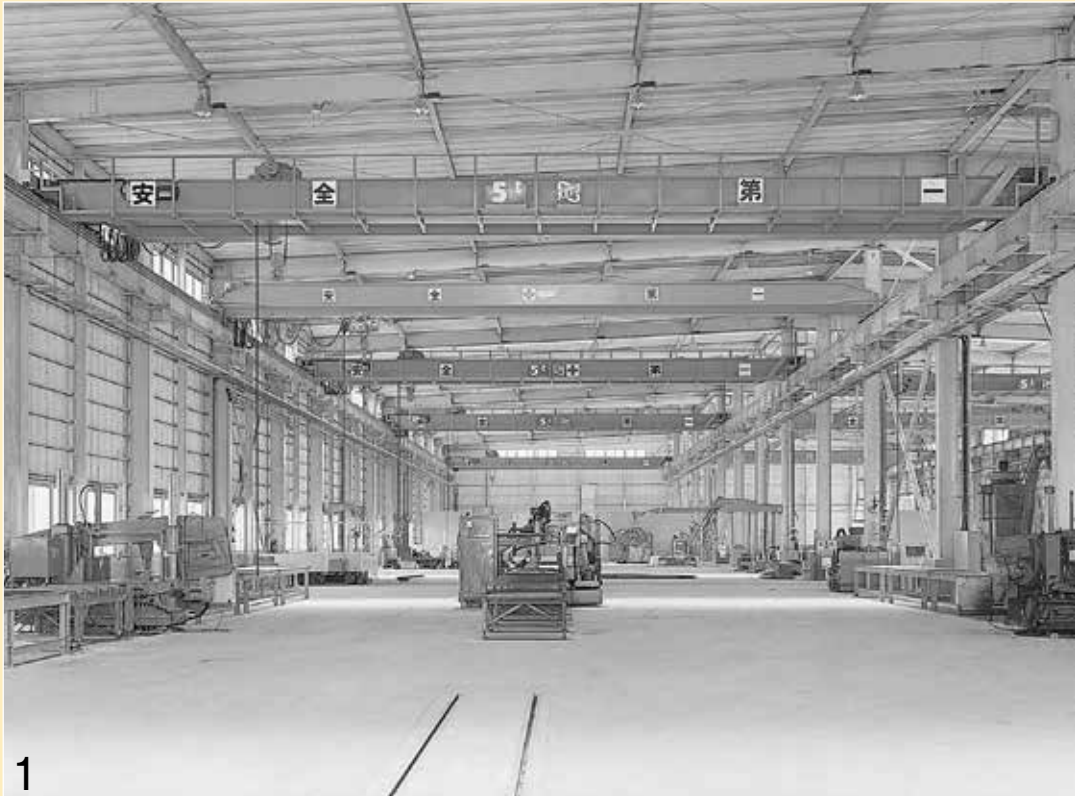

Overhead cranes

- 1: 5 t Double girder
- 2: 10/5 t Double girder
- 3: 3 t Double girder

KITO CRANE APPLICATIONS

[Low-head cranes / Gantry cranes / Jib cranes]

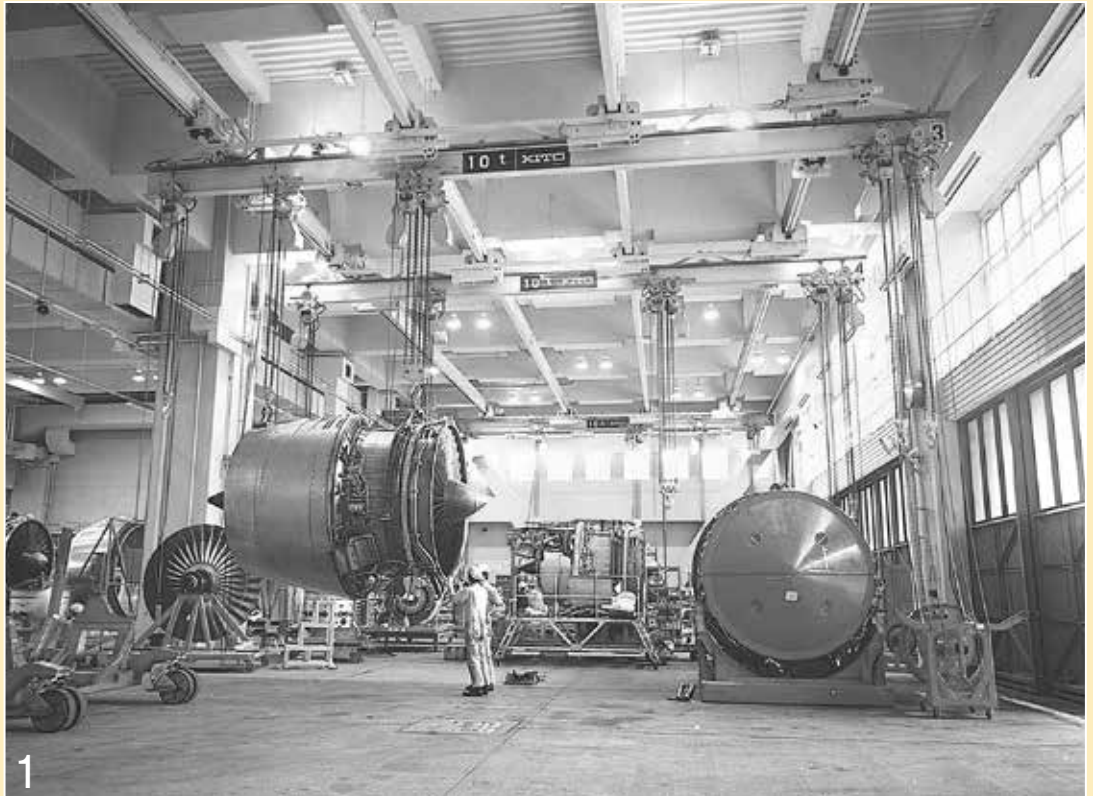

Low-head cranes

- 1: 10 t Single girder
- 2: 1 t Single girder
- 3: 1 t Single girder





Gantry cranes

4: 20 t Gantry cranes

5: 5 t Single leg gentry crane



Jib cranes

6: 6 t Pillar type

7: 2 t Wall Type

KITO CRANE APPLICATIONS

[Special application cranes]





Special application cranes

- 1: 10 t System crane for jet engine transportation
- 2: Auto crane for heat treatment furnace
- 3: Auto crane
- 4: Sliding crane
- 5: Explosion-proof type crane
- 6: Transfer crane
- 7: Turn table type

KITO CRANE APPLICATIONS

[Special application cranes]

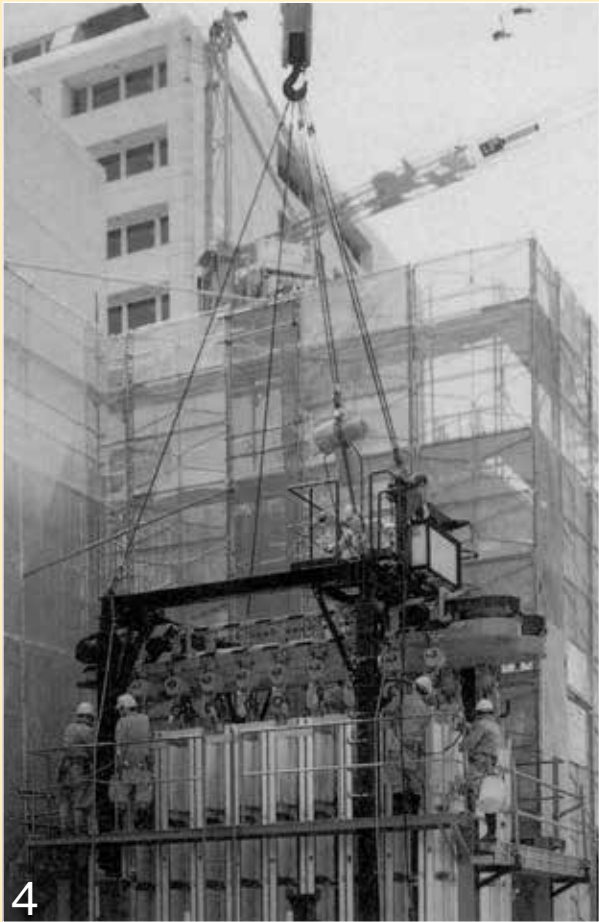
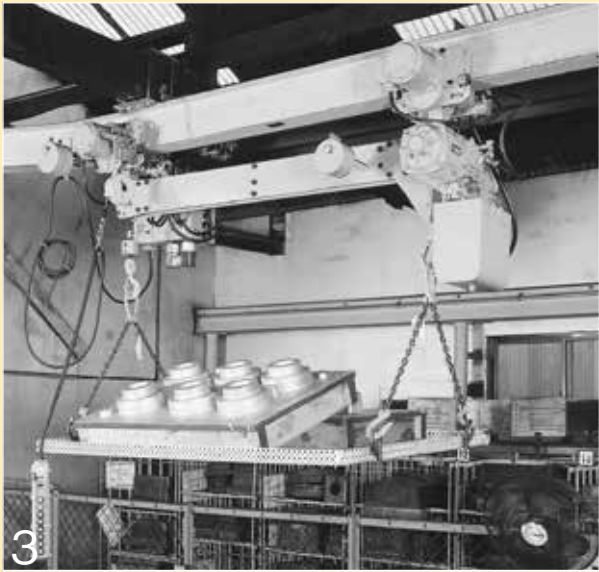

- 1: Special crane lifting jet engine
- 2: Crane with rope hoist
- 3: Twin hook type special hoist
- 4: Special hoists for arranging building window frame

OVERHEAD CRANES [Single Girder]

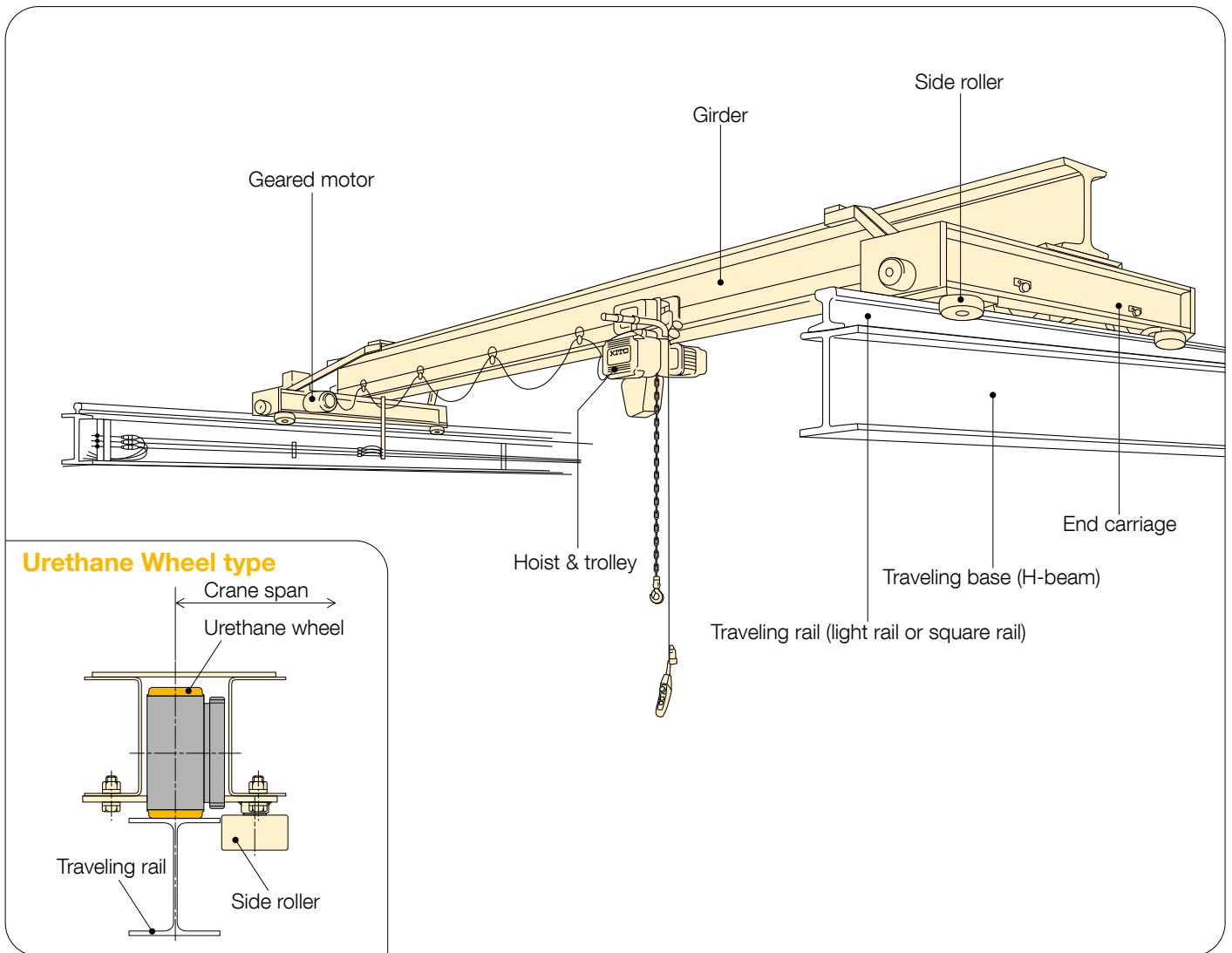

The single girder overhead crane can be installed on traveling rails on the brackets of building pillars. This type of crane has a relatively larger capacity and can utilize space below ceiling rafters, and so a wider lifting range is assured. Guiding the path using side rollers provides smooth traveling and the girders can be designed according to the rated load and span. Moreover, the shorter overall length of the end carriage and the geared-motor installation in optimum position allows for a more effective use of work space.

A dual speed type crane is available for speed-controlled operations. There is also a urethane wheel type version of this crane that effectively reduces noise and vibrations in travel. It is recommended for factories near residential areas, duplex office-homes and for operation at night. Running urethane wheels on the top flange of the H-beam reduces noise and vibration in travel. With these cranes it is not necessary to install a light rail, thus reducing installation costs and time.

Single speed crane

This crane employs geared motors specially designed by KITO to ensure smooth starts and stops. It is suited for general work.

Dual speed crane

This crane is capable of pendant button-controlled speed shift between low and high speed (reduction ratio of 4:1). It is suited for work requiring varied speed operation.

Manual geared type crane

This manual geared type crane balances travel smoothly by synchronizing the driving wheels on both sides. With a relatively shorter travel distance, it is suited for low frequency work.

Optional SOFTRUN device

This device electrically controls motor speed which enables to accelerate smoothly in travel and minimizes load swing at start-up.

It is highly suited for handling high inertia loads or operating long span cranes.

OVERHEAD CRANE [Double Girder]

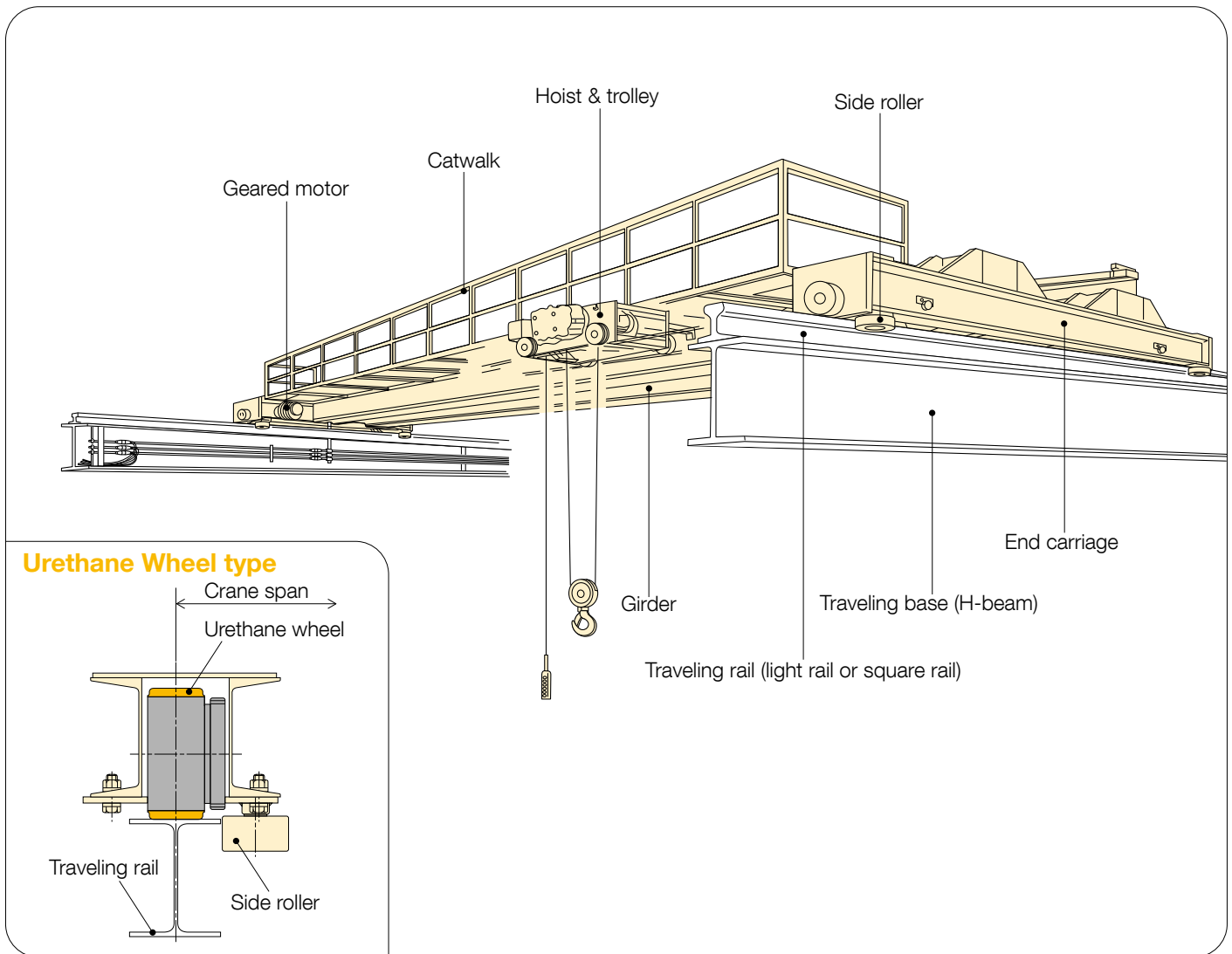

The double girder overhead crane can be installed on traveling rails on the brackets of building pillars. The double rail type trolley runs along parallel girders suitable for larger capacity cranes, and also can utilize space below ceiling rafters, and so a wider lifting range assured. Smooth traveling is obtained using a guide mechanism with side rollers, and the girder construction can be designed according to the rated load and span. Moreover, the shorter overall length of the end carriage allows for a more effective use of the work space.

A dual speed type crane is available for speedcontrolled operations. There is also a urethane wheel type crane that effectively reduces noise vibration in travel. It is recommended for factories near residential areas, duplex office-homes and for operation at night. Running urethane wheels on the top flange of the H-beam reduces noise and vibration in travel. With these cranes, it is not necessary to install a light rail thus reducing on installation costs and time.

Single speed crane

This crane employs geared motors specially designed by KITO to ensure smooth starts and stops. It is suited for general work.

Dual speed crane

This crane is capable of pendant button-controlled speed shift between low and high speed (reduction ratio of 4:1). It is suited for work requiring varied speed operation.

Optional SOFTRUN device

This device electrically controls motor speed which enables to accelerate smoothly in travel and minimizes load swing at start-up.

It is highly suited for handling high inertia loads or operating long span cranes.

LOW-HEAD CRANES

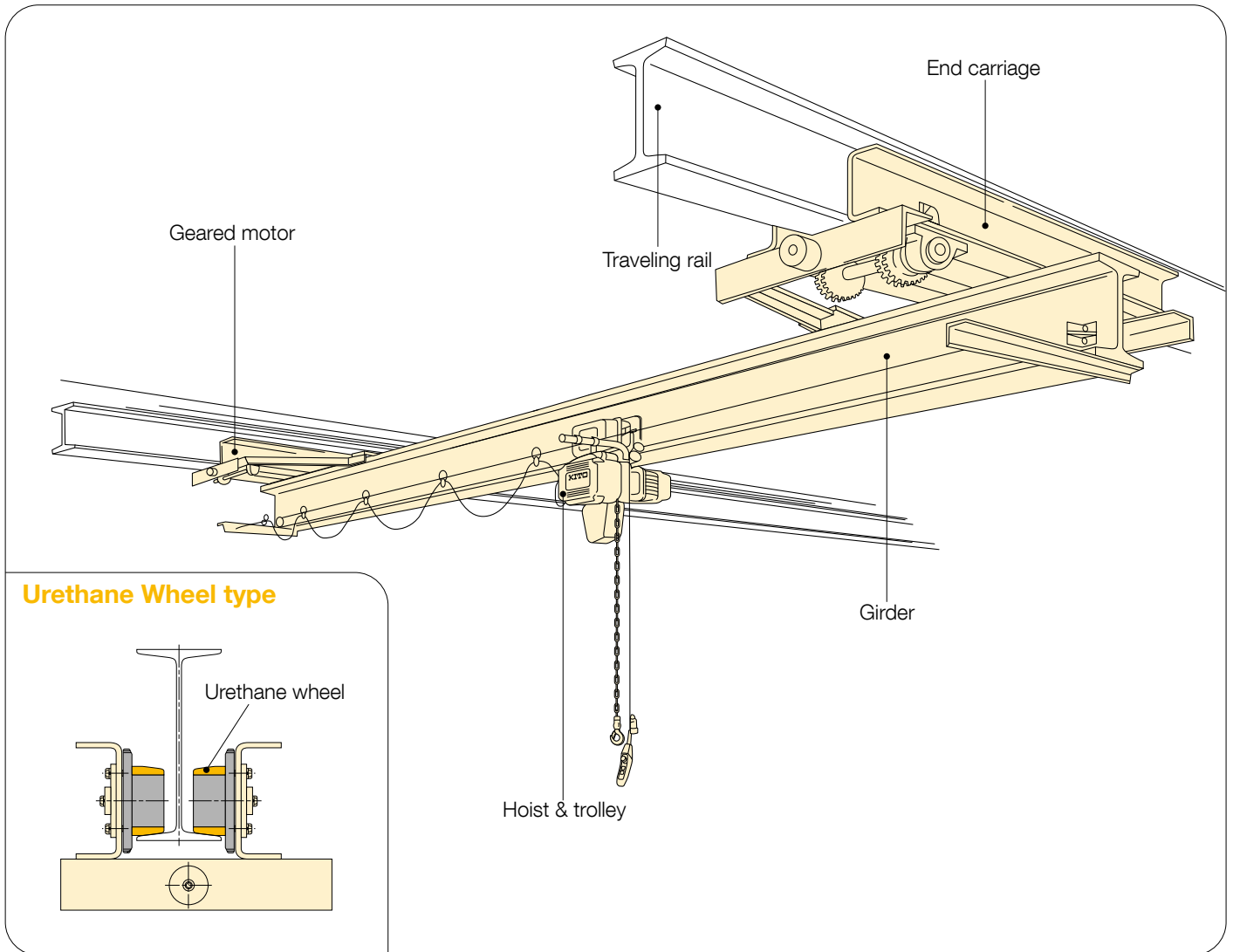

The low-head crane is suspended from the traveling rail (I-beam) which is fixed to the ceiling rafters of the building. Because the traveling rail location and span can be freely chosen, the crane can be designed to suit production line processes. The detaching design for the track wheel and its axle reduces installation and maintenance time.

A dual speed type crane is available for speedcontrolled operation. There is also a urethane wheel type version of the crane that effectively reduces noise and vibration in travel. It is recommended for factories near residential areas, duplex office-homes, and for operation at night.

Single speed crane

This crane employs geared motors specially designed by KITO to ensure smooth starts and stops. It is suited for general work.

Dual speed crane

This crane is capable of pendant button-controlled speed shift between low and high speed (reduction ratio of 4:1). It is suited for work requiring varied speed operation.

Manual geared type

This manual geared type version of the crane balances travel smoothly by synchronizing the driving wheels on both sides. With a relatively shorter travel distance, it is suited for low frequency work.

Manual plain type (Low-head only)

This is the simplest manual type of crane and lifting and traveling are operated by hand. It is suited for light work.

Optional SOFTRUN device

This device electrically controls motor speed which enables to accelerate smoothly in travel and minimizes load swing at start-up. It is highly suited for handling high inertia loads or operating long span cranes.

END CARRIAGE CAPACITY

- W.L.L.: indicates the maximum mass (working load limit) for general use.
- Traveling speeds are show on pages 18 to 23.

Type	W.L.L. (t)	Span (m)								Page
		3	6	9	12	15	18	21	27	
Motorized	Overhead	1	EO010-12			EO010-18			18	
		2	EO010-12			EO020-18				
		3				EO030-18				
		5	EO050-9		EO050-18			EO050-21		
		7.5	EO010-12			EO100-18				
		10	EO010-12			EO100-18				
	Low-head	1	EL010-6	EL010-9	EL010-12	22				
		2	EL020-6	EL020-9	EL010-12					
		3	EL030-6	EL010-12						EL030-15
		5	EL050-9		EL050-15					
Urethane Wheel Type	Overhead	1	CEO010-9			CEO010-18			19	
		2	CEO020-12							
		3				CEO030-15	CEO030-18	CEO030-21		
		5	CEO050-12			CEO050-18				
		7.5				CEO075-18				
		10	CEO100-12			CCEO100-21 CCEO100-21H				
	Low-head	1	CEO010-9			23				
		2	CEO020-9							
	Double Girder	Overhead	3	WEO030-15			WEO030-21		WEO030-27	20
			5				WEO050-21		WEO050-27	
7.5						WEO075-21		WEO075-27		
10						WEO100-21		WEO100-27		
15			WEO100-15					WEO150-27 WEO150-27H		
20								WEO200-27 WEO200-27H		
Urethane Wheel Type		3	CWEO030-15			CWEO030-21		CWEO030-27	21	
		5								
		7.5	CWEO075-15			CWEO075-21		CWEO075-27		
		10								
		15	CWEO150-15			CWEO150-21				
		20	CWEO200-15			CWEO200-21		CWEO200-27		
Manual Type	Overhead	Geared	1	GO010-12			24			
			2	GO020-12						
			3	GO030-12						
			5	GO050-12						
	Low-head	Plain	0.5	PL005-3					25	
			1	PL010-6	PL010-9					
		Geared	1	GL010-6	GL010-12			24		
			2	GL020-6	GL020-12					
			3	GL030-6	GL030-12					
			5	GL050-6	GL050-12					

- Optional SOFTRUN is recommended for [] color models.
- For dual listings, models on the upper line are the low, standard and dual speed end carriages, whereas models on the lower line are the high speed end carriages. Single listings show the low, standard, high and dual speed end carriages.
- *Available on request.
- W.L.L.: Working Load Limit (t).

Features of end carriages

- To meet customer needs, we have raised performance while offering more standardized models. The track wheel is now made of a carbon steel construction and is, thus, durable and long-lasting (excluding the plain type crane which is made from heat-treated hot-rolled steel plates)
- Products are primer-coated which allows customers to choose the desired top coat color (Munsell 6YR6/14 is painted for plain type cranes).
- Punch-mark on end carriages for easy centering and drilling for girders.

Overhead end carriages	<ul style="list-style-type: none"> ○ Track wheel maintenance is easy because of the open frame construction. ○ Travel is smooth because of a guide mechanism with side rollers.
Overhead urethane wheel type end carriages	<ul style="list-style-type: none"> ○ Durability has been improved with our own developed urethane wheels. ○ The urethane wheels run directly over the top flange of the H-beam, thus reducing noise and vibration in travel. It is not necessary to install a light rail thus reducing installation costs and time. ○ Travel is smooth because of a guide mechanism with side rollers.
Low-head end carriages	<ul style="list-style-type: none"> ○ Both the track wheel and track wheel axle are designed for easy detaching thus reducing installation and maintenance time. ○ Anti-drop plates are equipped on the carriage (for CSA).
Low-head urethane wheel type end carriages	<ul style="list-style-type: none"> ○ This end carriage employs durable urethane wheels developed by KITO and an idling gear in reinforced nylon resin and reduces noise and vibrations in travel. ○ Both the track wheel and track wheel axle are designed for easy detaching thus reducing installation maintenance time.
Manual plain type end carriage	<ul style="list-style-type: none"> ○ The hand pulling operation has become smoother and easier with a pressed metal wheel (0.5 t span 3 m and 1 t span 6 m) and side rollers (1 t span 9 m).

How to read carriage types

EL 010 9
WEO 150 27

Rated load

Ex.: 010 = 1 t, 150 = 15 t

Span

Ex.: 9 = 9 m, 27 = 27 m

Types

EO	Motorized overhead end carriages
EL	Motorized low-head end Carriages
CEO	Urethane wheel motorized overhead end carriages
CEL	Urethane wheel motorized low-head end carriages
WEO	Motorized overhead double girder end carriages
CWEO	Urethane wheel motorized overhead double girder end carriages
GO	Geared type manual overhead end carriages
GL	Geared type manual low-head and carriages
PL	Plain type manual low-head end carriages

GEARED MOTOR CAPACITY

Type		W.L.L. (t)	Span (m)								
			3	6	9	12	15	18	21	27	
Motorized	Overhead	1	G1MO025□-□ 0.25 kW			G1MO025□-□ 0.25 kW			G1MO025□-□ 0.25 kW		
		2	G1MO025□-□ 0.25 kW			G1MO025□-□ 0.25 kW			G1MO025□-□ 0.25 kW + 0.4 kW		
		3	G1MO025□-□ 0.25 kW	G1MO040T-□ 0.25 kW + 0.4 kW		G1MO025□-□ 0.25 kW			G1MO040T-□ 0.25 kW + 0.4 kW		
		5	G1MO025□-□ 0.25 kW	G1MO040T-□ 0.25 kW + 0.4 kW		G1MO040□-□ 0.4 kW	G1MO075T-□ 0.4 kW + 0.75 kW				
		7.5	G1MO075□-□ 0.75 kW	G1MO150T-□ 0.75 kW + 1.5 kW			G1MO075□-□ 0.75 kW		G1MO075□-□ 0.75 kW		
		10				G1MO150T-□ 0.75 kW + 1.5 kW			G1MO105T-□ 0.75 kW + 1.5 kW		
	Low-head	1	G1ML025□-□ 0.25 kW	G1ML025□-□ 0.25 kW	G1ML025□-□ 0.25 kW	G1ML040□-□ 0.4 kW		Available on your request			
		2	G1ML025□-□ 0.25 kW	G1ML025□-□ 0.25 kW	G1ML025□-□ 0.25 kW						
		3	G1ML025□-□ 0.25 kW	G1ML025□-□ 0.25 kW		G1ML040T-□ 0.25 kW + 0.4 kW					
		5	G1ML040□-□ 0.4 kW	G1ML075T-□ 0.4 kW + 0.75 kW		G1ML075□-□ 0.75 kW					
Urethane Wheel Type	Overhead	1	G1MO025□-□ 0.25 kW			G1MO040□-□ 0.4 kW		G1MO075□-□ 0.75 kW			
		2	G1MO040□-□ 0.4 kW			G1MO075□-□ 0.75 kW					
		3	G1MO075□-□ 0.75 kW								
		5	G1MO075□-□ 0.75 kW	G1MO150T-□ 0.75 kW + 1.5 kW		G1MO150□-□ 1.5 kW		G1MO150□-□ 1.5 kW			
		7.5	G1MO150□-□ 1.5 kW			G1MO150□-□ 1.5 kW					
		10				G1MO150□-□ 1.5 kW		G1MO150□-□x2 1.5 kWx2			
	Low-head	1	G1ML025□-□ 0.25 kW			Available on your request					
		2	G1ML040□-□ 0.4 kW	G1ML075T-□ 0.4 kW + 0.75 kW							
	Double Girder	Overhead	3	G1MO025□-□ 0.25 kW	G1MO040T-□ 0.25 kW + 0.4 kW					G1MO040□-□ 0.4 kW	G1MO075T-□ 0.4 kW + 0.75 kW
			5	G1MO040□-□ 0.4 kW	G1MO075T-□ 0.4 kW + 0.75 kW		G1MO075□-□ 0.75 kW		G1MO150T-□ 0.75 kW + 1.5 kW		G1MO075□-□ 0.75 kW
7.5			G1MO075□-□ 0.75 kW							G1MO075□-□ 0.75 kW	G1MO150T-□ 0.75 kW + 1.5 kW
10			G1MO150T-□ 0.75 kW + 1.5 kW			G1MO075□-□ 0.75 kW		G1MO150T-□ 0.75 kW + 1.5 kW		G1MO150□-□ 1.5 kW	
15			G1MO150□-□ 1.5 kW								
20			G1MO150□-□ 1.5 kW	G1MO150□-□x2 1.5 kWx2		G1MO150□-□ 1.5 kW		G1MO150□-□x2 1.5 kWx2			
Urethane Wheel Type		3	G1MO075□-□ 0.75 kW	G1MO150T-□ 0.75 kW + 1.5 kW					G1MO150□-□ 1.5 kW		
		5	G1MO150□-□ 1.5 kW								
		7.5	G1MO150□-□ 1.5 kW								
		10	G1MO150□-□x2 1.5 kWx2			G1MO150□-□x2 1.5 kWx2					
15	G1MO150□-□x2 1.5 kWx2			G1MO150□-□x2 1.5 kWx2							
20	G1MO150□-□x2 1.5 kWx2			G1MO150□-□x2 1.5 kWx2		G1MO150□-□x2 1.5 kWx2					

- 0.4 kW+0.75 kW means that the 0.75 kW motor is used with an original reduction gear of 0.4 kW to increase motor output (Speed T = 30/36 m/min. as shown on page 17)
- 1.5 kWx2 means 2 geared motors are used on 1 end carriage (on side): 4 driving motor type.
- For dual listings, models on the upper line are the low, standard and dual speeds end carriages, whereas models on the lower line are the high speed end carriages. Single listings show the low, standard, high and dual speed end carriages.
- *Available on request (2.2 kWx2 for 30/36 m/min. speed).
- W.L.L.: Working Load Limit (t).

Features of geared motors

- KITO cranes employ a geared motor with an electromagnetic brake. Brake torque is adjustable from 0 to 50% (for 0.25 kW :from 30 to 80%) of the rated torque of the motor, thus the load swing can be minimized by adjusting the brake torque.
- The motor uses a helical gear, which reduces noise during operation.
- SOFTRUN devices are available to provide smooth starts and minimize swing.
- Motors are available in three different single speed (10/12, 20/24, and 30/36 m/min 50/60 Hz) types and one dual speed (20/5 24/6 m/min 50/60 Hz) type (reduction ratio of 4:1) and they make work more efficient.

How to read types (example)

G1MO025 L-S

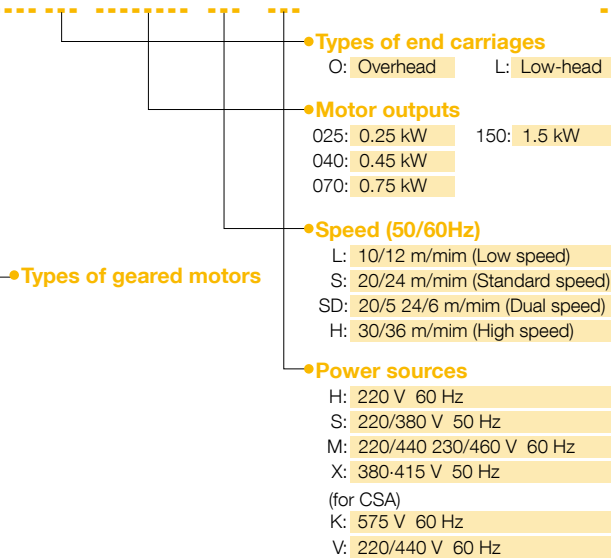

G1MO040 T-S

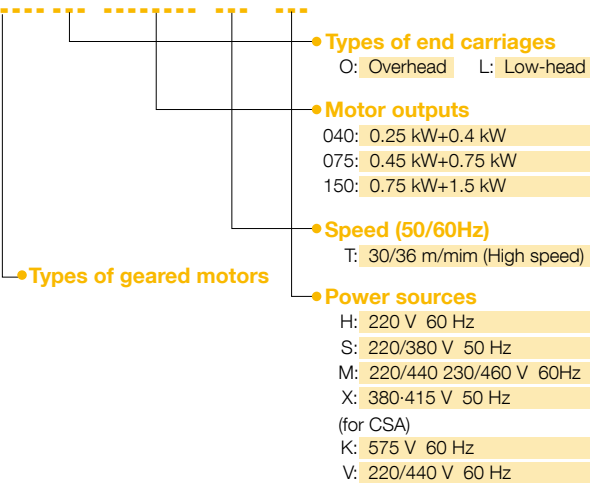

How to order end carriages (example)

When ordering an end carriage and geared motor separately

Ex. Overhead end carriage 1 t span 12 m.

Geared motor for traveling speed 20 m/min, motor output 0.25 kW, and electric voltage 380 V 50 Hz.

• **End carriage**

EO010-12 shown on page 18

• **Geared motor**

G1MO025S-X shown on page 26

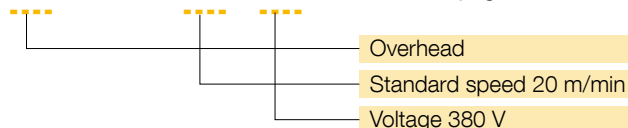

When ordering an end carriage and geared motor as a complete unit

Ex. Overhead end carriage 1 t span 12 m, traveling speed 20 m/min and electric voltage 380 V 50 Hz.

• **Complete unit**

EO010-12-S-X shown on page 18

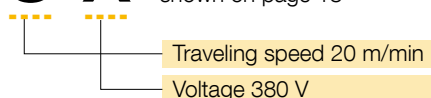

END CARRIAGE SPECIFICATIONS

Motorized Overhead End Carriage Specifications

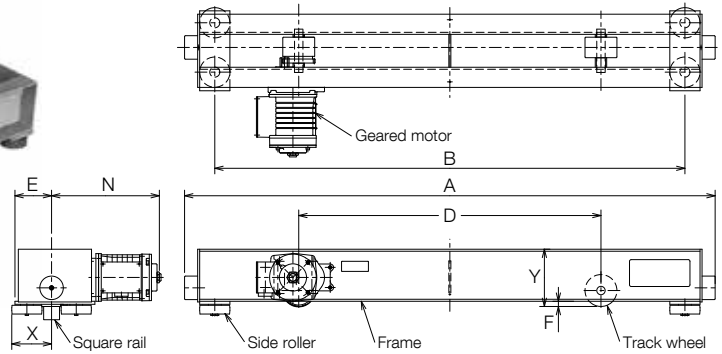

Ex. Above photo shows EO030-12
Some types of motors are mounted in parallel on the frames.

W.L.L. (t)	Max. span (m)	Type	Traveling motor output (kWx2) 50/60 Hz (m/min)				Applicable square rail (mm)	Max. wheel pressure (kN)	Wheel diameter (mm)	Dimensions (mm)							Mass Net (Weight) (kg)	
			L	S	H	SD				A	B	D	E ^{*1}	F	N ^{*2}	X		Y
			10/12	20/24	30/36	20:5/24:6												
1	12	☆EO010-12			0.25		□32-□40 □38-□45	9.31	95	1580	1400	900	109	15.5	321	119	171	132
	18	EO010-18						17.6	125	2280	2100	1200	124		325		191	197
	21	EO030-21			0.4		□45-□50	31.4	175	2691	2505	1400	144		326	123	221	380
2	12	☆EO020-12			0.25		□32-□40 □38-□45	17.6	125	1580	1400	900	114		325	119	176	146
	18	EO020-18	0.25	0.25		0.25/0.063			2280	2100	1200	124	20.5				221	212
	21	EO030-21						31.4	175	2691	2505	1400	144		326			380
3	12	☆EO030-12					□45-□50	20.6	140	1580	1400	900	114		325	123	176	150
	18	EO030-18			0.4			23.5	155	2280	2100	1200	149				221	252
	21	EO030-21						31.4	175	2691	2505	1400	144		326			380
5	9	☆EO050- 9							175	1490	1300	800	124		323		224	197
	18	EO050-18	0.4	0.4	0.75	0.4 /0.1	□50	44.1	210	2296	2100	1200	138		376	143		374
	21	EO050-21							210	2696	2500	1400	163				264	496
7.5	12	☆EO100-12						73.5	250	1645	1405	900	138				224	384
	18	EO100-18						79.4	300	2345	2105	1200	163	23.5			264	586
	21	EO100-21							300	2745	2505	1400	183				324	724
10	12	☆EO100-12	0.75	0.75	1.5	0.75/0.19	□55-□60	73.5	250	1645	1405	900	138		445	162	224	384
	18	EO100-18						79.4	300	2345	2105	1200	163				264	586
	21	EO100-21							300	2745	2505	1400	183				324	724

•W.L.L.: Working Load Limit (t).

*1: The size including the projection of the side roller plate.

*2: The size with the standard speed (s) geared motor.

☆: Geared motors installed in diagonal positions as shown in the above photo.

•When planning a girder or cart, contact your nearest Kito distributor.

Urethane Wheel Motorized Overhead End Carriage Specifications

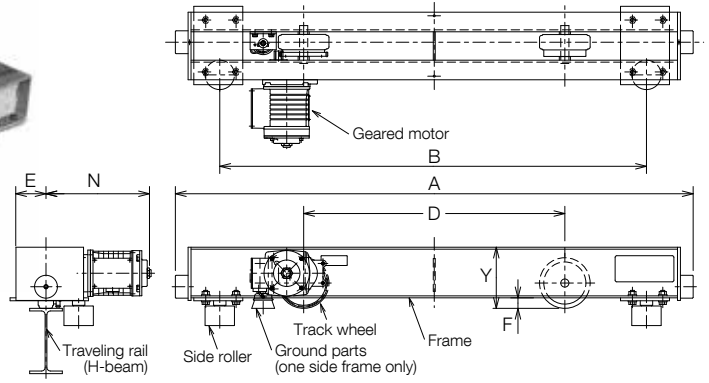

Ex. Above photo shows EO030-15
Some types of motors are mounted in parallel on the frames.

W.L.L. (t)	Max. span (m)	Type	Traveling motor output (kWx2) 50/60 Hz (m/min)				Applicable traveling rail (mm)	Max. wheel pressure (kN)	Recommended wheel pressure (kN)	Wheel diameter (mm)	Dimensions (mm)						Mass Net Weight (kg)		
			L	S	H	SD					A	B	D	E ⁴	F	N ⁵		Y	
			10/12	20/24	30/36	20:5/24:6													
1	9	☆CEO010-9	0.25	0.25	0.25	0.25/0.063	100-125-150	7.8	7.4	155	1586	1307	800	110		317	188	156	
	12	☆CEO020-12								175	1696	1445	900	131	32	383		202	
	18	CEO010-18	0.4	0.4	0.4	0.4 /0.1		14.7	13.9	175	2356	2105	1200					233	265
	21	CEO030-21	0.75	0.75	0.75	0.75/0.19		33.3	25.0	220	2792	2499	1400	155	39	460	239	502	
2	12	☆CEO020-12	0.4	0.4	0.4	0.4 /0.1		14.7	13.9	175	1696	1445	900	131	32	383	188	202	
	15	CEO030-15									2082	1761	1000					384	
	18	CEO030-18									2422	2101	1200					398	
	21	CEO030-21									2792	2499	1400					502	
3	15	CEO030-15	0.75	0.75	0.75	0.75/0.19		33.3	25.0	220	2082	1761	1000	155		460	239	384	
	18	CEO030-18					150-175-200				2422	2101	1200					398	
	21	CEO030-21									2792	2499	1400					502	
5	12	☆CEO050-12									1852	1531	900		39			355	
	18	CEO050-18						41.2	31.0	260	2402	2106	1200	153		559		543	
	21	CEO075-21									2821	2506	1400	184			279	665	
7.5	12	☆CEO100-12			1.5						2081	1766	900	177			239	525	
	18	CEO075-18	1.5	1.5		1.5 /0.38		61.7	46.2	340	2421	2106	1200			553	279	627	
	21	CEO075-21									2821	2506	1400	184				665	
10	12	☆CEO100-12									2081	1766	900	177			239	525	
	21	CEO100-21			1.5x2		200-250	81.3	60.0	440	2849	2509	1400	234	46	592	346	1027 (1220)	

•W.L.L.: Working Load Limit (t).

•Weight in parentheses is for high speed (H).

*1: Contact your nearest Kito distributor for sizes other than listed above.

*2: Wheel pressure under the W.L.L. beneath the end carriage with standard girder and maximum span to verify endurance of the structure.

*3: In case of regular use of more than 80% of W.L.L. or frequent operation at a particular position, select an end carriage to make the wheel pressure the same as or less than the recommended wheel pressure.

*4: The size including the projection of the side roller plate.

*5: The size with the standard speed (s) geared motor.

☆: Geared motors installed in diagonal positions as shown in the above photo.

•When planning a girder or cart, contact your nearest Kito distributor.

END CARRIAGE SPECIFICATIONS

Motorized Overhead Double Girder End Carriage Specifications

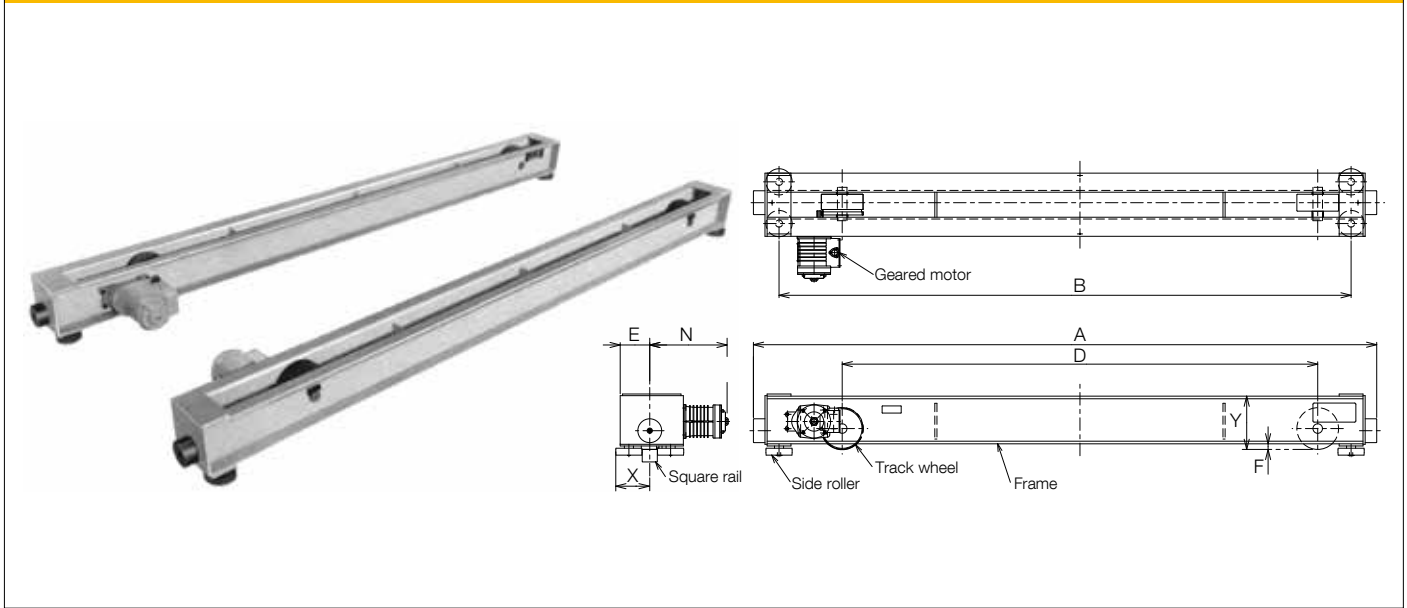

W.L.L. (t)	Max. span (m)	Type	Traveling motor output (kWx2) 50/60 Hz (m/min)				Applicable square rail (mm)	Max. wheel pressure (kN)	Wheel diameter (mm)	Dimensions (mm)							Mass Net (Weight) (kg)	
			L	S	H	SD				A	B	D	E ^{*1}	F	N ^{*2}	X		Y
			10/12	20/24	30/36	20:5/24:6												
3	15	WEO030-15	0.25	0.25	0.4	0.25/0.063		31.4	175	2615	2400	1995	124		325			382
	21	WEO030-21								2845	2630	2195						449
	27	WEO030-27	0.4	0.4	0.75	0.4 /0.1	□50	44.1	210	3395	3180	2140	128		375	143	224	504
5	15	WEO030-21								2845	2630	2195						449
	21	WEO050-21								3095	2855	2390	134		444			554
	27	WEO050-27						73.5		3425	3185	2590		23.5				736
7.5	21	WEO075-21								3098	2855	2395					274	686
	27	WEO075-27	0.75	0.75		0.75/0.19	□55-□60	79.4		3478	3235	2740	138		445	162	324	799
	15	WEO075-21			1.5			73.5		3098	2855	2395					274	686
10	21	WEO100-21						82.3	300	3288	3045	2540					324	828
	27	WEO100-27						100	350	3698	3430	2840			529		328	1136
	15	WEO100-27																
15	27	WEO150-27	1.5	1.5		1.5 /0.38	□55-□60-□65						150	27.5		189		1448 (1588)
	15	WEO150-27			1.5x2			131	400	4028	3760	3150			530		408	1945 (2083)
	27	WEO200-27						162	450	4528	4260	3500			531			

•W.L.L.: Working Load Limit (t).

•Weights in parentheses are for high speed (H).

*1: The size including the projection of the side roller plate.

*2: The size with the standard speed (s) geared motor.

•When planning a girder or cart, contact your nearest Kito distributor.

Urethane Wheel Motorized Overhead Double Girder End Carriage Specifications

● One motor drive type

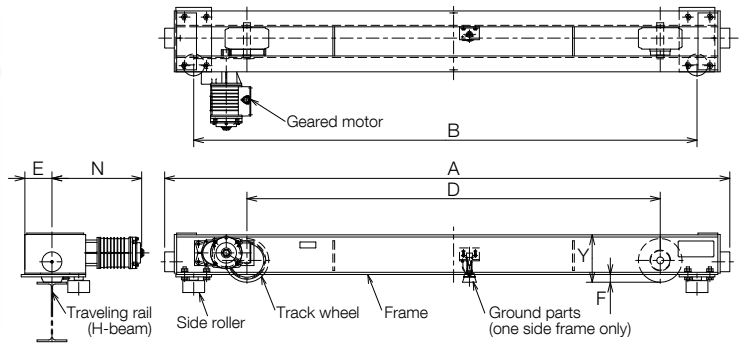

● Two motor drive type (※)

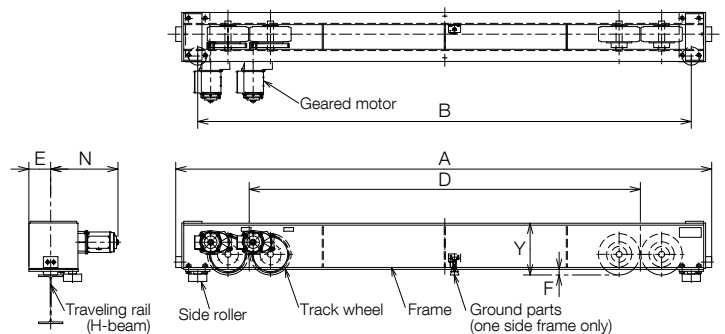

W.L.L. (t)	Max. span (m)	Type	Traveling motor output (kWx2) 50/60 Hz (m/min)				Applicable square rail (mm)	Max. wheel pressure (kN)	Recommended wheel pressure (kN)	Wheel diameter (mm)	Dimensions (mm)						Mass Net Weight (kg)	
			L	S	H	SD					A	B	D	E ⁴	F	N ⁵		Y
			10/12	20/24	30/36	20:5/24:6												
3	15	CWEO030-15	0.75	0.75		0.75/0.19	150-175-200	33.3	25.0	220	2851	2539	2085	155		459	239	524
	21	CWEO030-21						41.2	31.0	260	3111	2796	2295	153		560		653
	27	CWEO030-27			1.5			43.1	32.3	300	3211	2896	2140	163		564	289	881
5	15	CWEO030-21	1.5	1.5		1.5 /0.38	175-200	41.2	31.0	260	3111	2796	2295	153	39	560	239	653
	21	CWEO075-15						61.7	46.2	340	3091	2776	2230	177		553		930
	27	CWEO075-21	1.5x2	1.5x2	1.5x2	1.5/0.38x2		41.2	31.0	260x2	3771	3456	2700	149		559	289	1160
7.5	15	CWEO075-15	1.5	1.5	1.5	1.5 /0.38	150-175-200	61.7	46.2	340	3091	2776	2230	177		553		930
	21	CWEO075-21					175-200	41.2	31.0	260x2	3771	3456	2700	149		559		1160
	27	CWEO075-27						43.1	32.3	300x2	4059	3701	2900	159	46	564	346	1438
10	15	CWEO075-21						200-250	41.2	31.0	260x2	3771	3456	2700	149	39	559	289
	21	CWEO075-27	1.5x2	1.5x2	1.5x2	1.5/0.38x2	43.1		32.3	300x2	4059	3701	2900	159		564	346	1438
	27	CWEO150-21									4412	4063	3220				426	1672
15	15	CWEO150-15					250-300	61.7	46.2	340x2	3992	3643	2790	180		554	346	1378
	21	CWEO150-21									4412	4063	3220					1672
	27	CWEO200-21			1						5172	4823	3800			593		2575
	27	CWEO200-21	—	—	2.2x2	—					5292	4943	3840		46	709		2700
20	15	CWEO200-15	1.5x2	1.5x2	1	1.5/0.38x2	250-300				4742	4393	3380		46	593		2214
	15	CWEO200-15	—	—	2.2x2	—		81.3	60.0	440x2	4872	4523	3420			709	426	2336
	21	CWEO200-21	1.5x2	1.5x2	1	1.5/0.38x2					5172	4823	3800	212		593		2575
	21	CWEO200-21	—	—	2.2x2	—					5292	4943	3840			709		2700
	27	CWEO200-27	1.5x2	1.5x2	1	1.5/0.38x2					5422	5073	4070			593		2944
	27	CWEO200-27	—	—	2.2x2	—					5552	5203	4110			709		3071

●W.L.L.: Working Load Limit (t).

*1: Contact your nearest Kito distributor for sizes other than listed above.

*2: Wheel pressure under the W.L.L. beneath the end carriage with standard girder and maximum span to verify the endurance of the structure.

*3: In case of regular use of more than 80% of W.L.L. or frequent operation at a particular position, select an end carriage to make the wheel pressure the same as or less than the recommended wheel pressure.

*4: The size including the projection of the side roller plate.

*5: The size with the standard speed (s) geared motor.

●When planning a girder or cart, contact your nearest Kito distributor.

END CARRIAGE SPECIFICATIONS

Motorized Low-head End Carriage Specifications

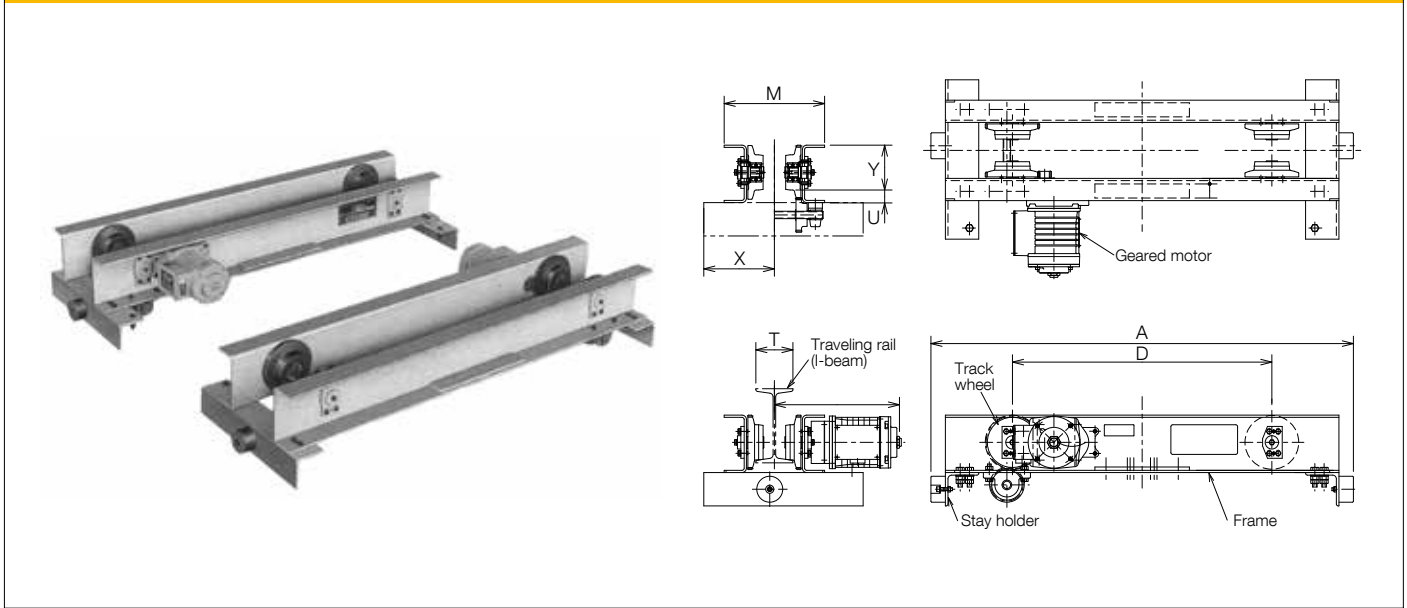

W.L.L. (t)	Max. span (m)	Type	Traveling motor output (kWx2) 50/60 Hz (m/min)				Applicable traveling rail (mm)	Max. wheel pressure (kN)	Wheel diameter (mm)	Dimensions (mm)						Mass (Net Weight) (kg)	
			L	S	H	SD				A	D	M	U	^{*1} N	X		^{*2} Y
			10/12	20/24	30/36	20:5/24:6											
1	6	EL010- 6							1140	700						132	
	9	EL010- 9	0.25	0.25	0.25	0.25/0.063	75-100-125-150	4.51	95	1500	1060	T+171	34	288+T/2	241-T/2	121	150
	12	EL010-12								1840	1400						164
	15	EL030-15	0.4	0.4	0.4	0.4 /0.1	125-150	15.7	140	2200	1760	T+231	40	336+T/2		174	340
2	6	EL020- 6							1140	700						152	
	9	EL020- 9	0.25	0.25	0.25	0.25/0.063	100-125-150	9.31	110	1500	1060	T+191	36	288+T/2		138	172
	12	EL020-12								1840	1400					165	202
	15	EL030-15	0.4	0.4	0.4	0.4 /0.1	125-150	15.7	140	2200	1760	T+231	40	336+T/2	281-T/2	174	340
3	6	EL030- 6	0.25	0.25	0.25	0.25/0.063	100-125-150	9.31	110	1140	700	T+191	36	288+T/2		165	160
	12	EL030-12			0.4												
	15	EL030-15	0.4	0.4	0.4	0.4 /0.1		15.7	140	2200	1760	T+231	40	336+T/2		174	340
5	9	EL050- 9	0.75	0.75	0.75	0.75/0.19	125-150	17.6	155	2200	1760	T+211	39	399+T/2	290-T/2	201	432
	15	EL050-15			0.75												

•W.L.L.: Working Load Limit (t).

*1: The size with the standard speed (s) geared motor.

*2: The height from the track surface of the traveling rail to the top of the end carriage.

•To reinforce a connecting part of the rails with a plate on the rail web, make sure that the plate has a clearance for the end carriage. (Do not install the plate for 75 mm width rails or on the rail track.)

•Use I-beam for the traveling rail.

•When planning a girder or cart, contact your nearest Kito distributor.

Urethane Wheel Motorized Low-head End Carriage Specifications

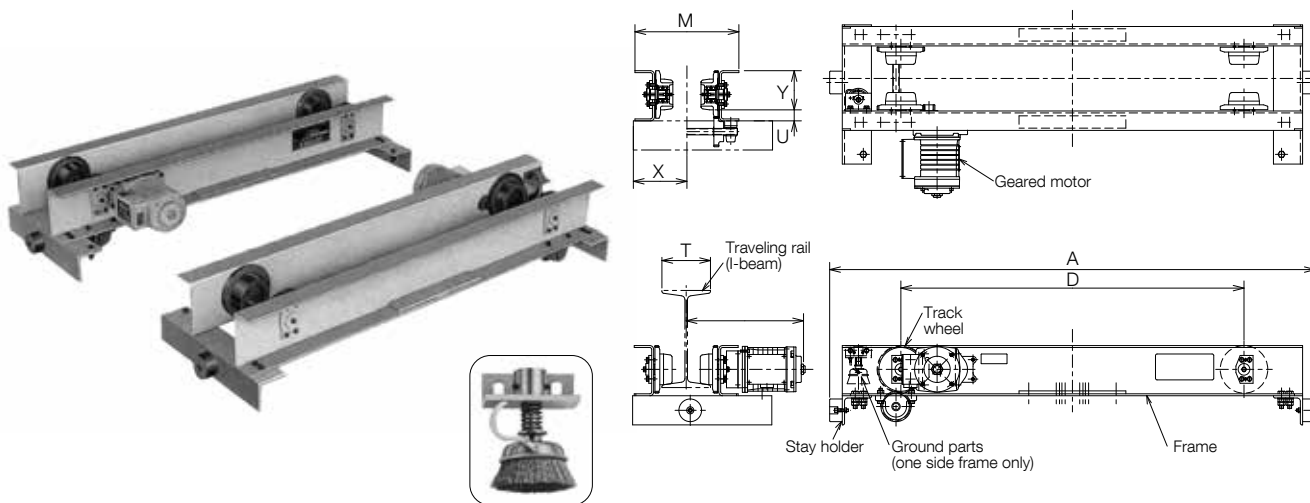

W.L.L. (t)	Max. span (m)	Type	Traveling motor output (kWx2) 50/60 Hz (m/min)				Applicable traveling rail (mm)	*1 Max. wheel pressure (kN)	*2 Recommended wheel pressure (kN)	Wheel diameter (mm)	Dimensions (mm)						Mass (Net Weight/ (kg)	
			L	S	H	SD					A	D	M	U	N ^{*3}	X		Y ^{*4}
			10/12	20/24	30/36	20:5/24:6												
1	9	CEL010-9	0.25	0.25	0.25	0.25/0.063	125-150	3.8	3.6	95	1500	1060	T+171	34	T/2+288	241-T/2	121	143
2	9	CEL020-9	0.4	0.4	0.75	0.4 /0.1		6.7	6.3	125			T+211	35	T/2+336	281-T/2	165	231

•W.L.L.: Working Load Limit (t).

*1: Wheel pressure under the W.L.L. beneath the end carriage with standard girder and maximum span to verify the endurance of the structure.

*2: In case of regular use of more than 80% of W.L.L. or frequent operation at a particular position, select an end carriage to make the wheel pressure the same as or less than the recommended wheel pressure.

*3: The size including the projection of the side roller plate.

*4: The size with the standard speed (s) geared motor.

•To reinforce a connecting part of the rails with a plate on the rail web, make sure that the plate has a clearance for the end carriage. (Do not install the plate for 75 mm width rails or on the rail track.)

•Use I-beam for the traveling rail.

•When planning a girder or cart, contact your nearest Kito distributor.

Track wheel and track wheel axle construction

With respect to a low-head end carriage, both the track wheel and track wheel axle are designed for easy detaching, thus reducing installation and maintenance time.

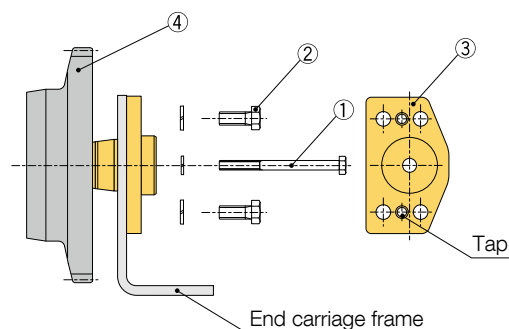
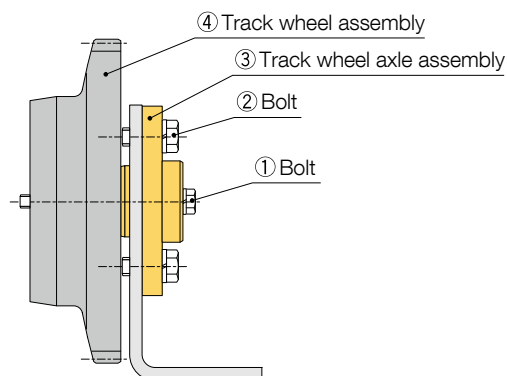

END CARRIAGE SPECIFICATIONS

Geared Overhead End Carriage Specifications

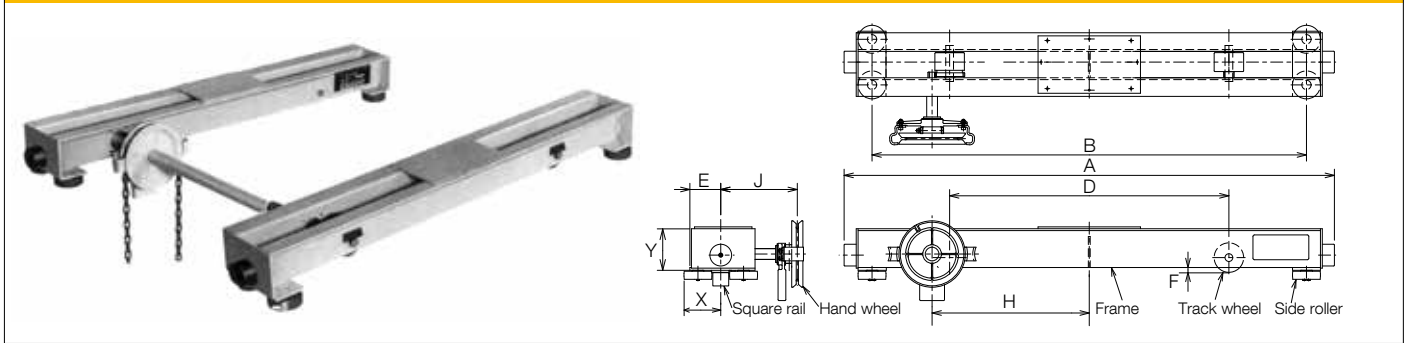

W.L.L. (t)	Max. span (m)	Type	Applicable square rail (mm)	Max. wheel pressure (kN)	Wheel diameter (mm)	Dimensions (mm)									Mass Net (Weight) (kg)
						A	B	D	E ^{*1}	F	H	J	X	Y ^{*2}	
1	12	GO010-12	□32-□38	9.31	95				100		507	247		147	99
2	12	GO020-12	□40-□45	17.6	125	1580	1400	900	120	15.5	509	252	119	172	130
3	12	GO030-12	□45-□50	20.6	140				135		521		123	202	156
5	12	GO050-12	□50	44.1	210	1590			119		561	257	143	205	224

•W.L.L.: Working Load Limit (t).

*1: The size including the projection of the side roller plate.

*2: The height from the track surface of the traveling rail to the top of the end carriage.

•When planning a girder or cart, contact your nearest Kito distributor.

Geared Low-head End Carriage Specifications

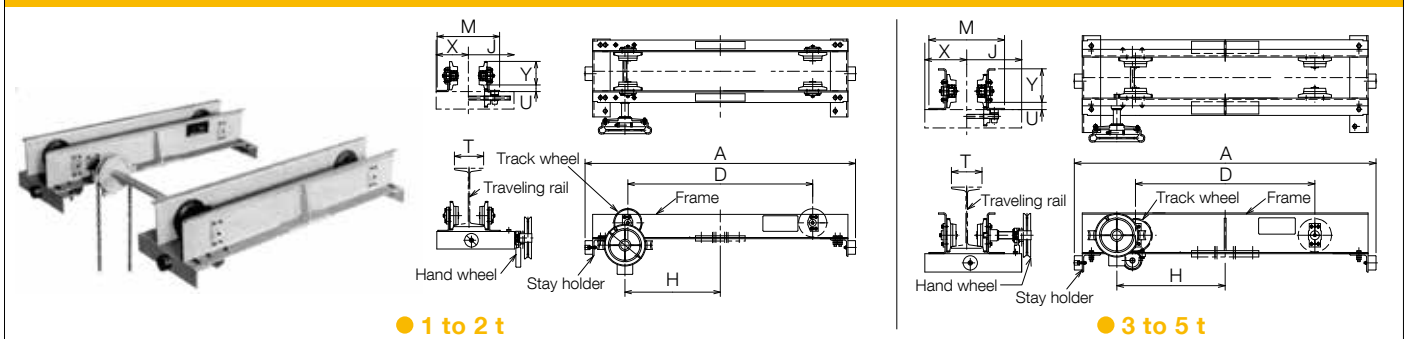

● 1 to 2 t

● 3 to 5 t

W.L.L. (t)	Max. span (m)	Type	Applicable traveling rail (mm)	Max. wheel pressure (kN)	Wheel diameter (mm)	Dimensions (mm)								Mass Net (Weight) (kg)
						A	D	H	J	M	U	J	Y ^{*1}	
1	6	GL010- 6	75-100-125-150	4.5	95	1390	950	490		T+171		241-T/2	121	106
	12	GL010-12				1840	1400	715		T+211	34			
2	6	GL020- 6	100-125-150	9.31	110	1480	1030	530		T+191			138	142
	12	GL020-12				1840	1400	715		T+201	36		281-T/2	145
3	6	GL030- 6	100-125-150	10.78	125	1480	880	531.3	T/2+221	T+221			165	162
	12	GL030-12				1840	1400	599.2	T/2+222	T+231	38			177
5	6	GL050- 6	125-150	15.7	140	1480	850	539	T/2+225	T+211	40		174	226
	12	GL050-12		17.6	155	1840	1400	579	T/2+234	T+249	39	315-T/2	188	292

•W.L.L.: Working Load Limit (t).

*1: The height from the track surface of the traveling rail to the top of the end carriage.

•To reinforce a connecting part of the rails with a plate on the rail web, make sure that the plate has a clearance for the end carriage. (Do not install the plate for 75 mm width rails or on the rail track.)

•Use I-beam for the traveling rail.

•When planning a girder or cart, contact your nearest Kito distributor.

Plain Low-head End Carriage Specifications

- No side rollers for 0.5 t (max. span 6 m) and 1 t (max. span 6 m)

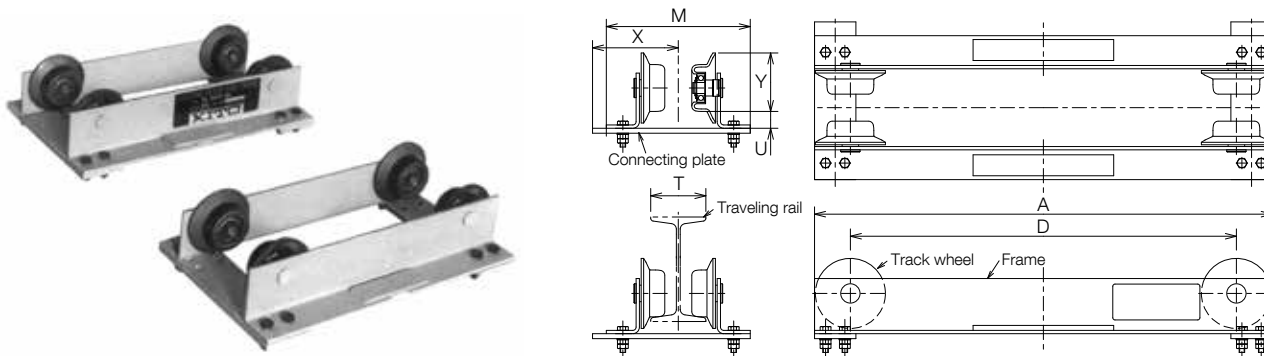

- Side rollers for 0.5 t and 1 t (max. span 6 m)

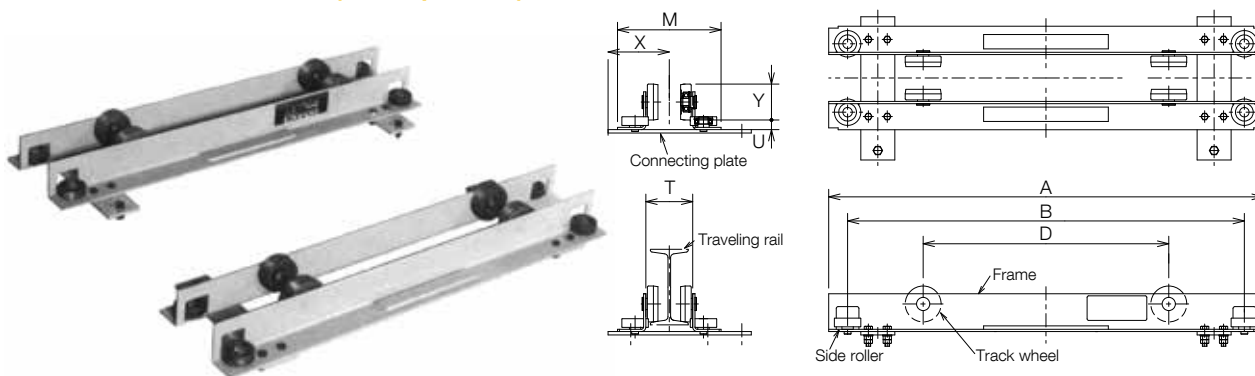

W.L.L. (t)	Max. span (m)	Type	Applicable traveling rail (mm)	Max. wheel pressure (kN)	Wheel diameter (mm)	Dimensions (mm)							Mass Net (Weight) (kg)
						A	B	D	M	U	X	Y	
0.5	3	PL005-3	75-100	1.76	71	470	—	350	T+157	25	206-T/2	89	27
	6	PL010-6	75-100-125	3.5	85	830	—	700	T+161	31		106	45
	9	PL010-9		3.92	95	1150	1050	650	T+174	26	212-T/2	95	71
1	6	PL010-6		3.5	85	830	—	700	T+161	31	206-T/2	106	45
	9	PL010-9	3.92	95	1150	1050	650	T+174	26	212-T/2	95	71	

●W.L.L.: Working Load Limit (t).

*: The height from the track surface of the traveling rail to the top of the end carriage.

●To reinforce a connecting part of the rails with a plate on the rail web, make sure that the plate has a clearance for the end carriage. (Do not install the plate for 75 mm width rails or on the rail track.)

●Use I-beam for the traveling rail except the size, 100×75×5.

●When planning a girder or cart, contact your nearest Kito distributor.

GEARED MOTOR SPECIFICATIONS

Dimensions

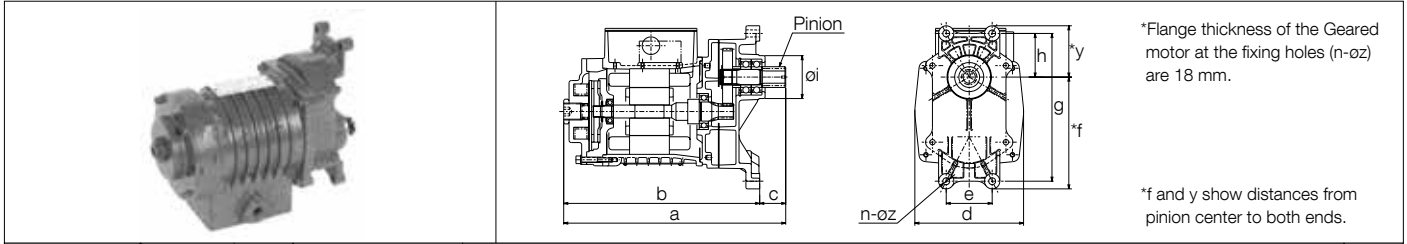

Type	Motor output (kW)	Pole	Power source	Dimensions (mm)											Mass (Net Weight) (kg)						
				a		b	c		d	e	f	y	g	h		oi	n	oz			
Overhead	Low-head	Overhead	Low-head																		
G1M□025L-□	0.25	4	H : 220 V 60 Hz M : 220/440 V 60 Hz or 230/460 V 60 Hz S : 220/380 V 50 Hz X : 380,415 V 50 Hz	290	281	256						67						11			
G1M□025S-□													82.2								
G1M□025H-□														67							
G1M□025SD-□	0.25/0.063	2/8	For CSA V : 220/440 V 60 Hz For CSA K : 575 V 60 Hz	324	315	290	25	142	60	146	70.6	193	57	56 ⁰ _{-0.046}				17.5			
				339		305												72	19		
G1M□040T-□	0.4	4	H : 220 V 60 Hz M : 220/440 V 60 Hz or 230/460 V 60 Hz S : 220/380 V 50 Hz X : 380,415 V 50 Hz	300	291	266	34					75.2					4	9	15.5		
G1M□040L-□													78							15	
G1M□040S-□														92.6							14
G1M□040H-□															215	66	74 ⁰ _{-0.046}				15
G1M□040SD-□				0.4/0.1	2/8	For CSA K : 575 V 60 Hz V : 220/440 V 60 Hz				29	156	70	161	78							16.5
G1M□075T-□	0.75	4		346	341	312												17			

- Brake: DC Disk Brake.
- Brake Torque: From 0 to 50% (for 0.25 kW:30 to 80%) of motor rated Torque.
- Dust and water protection: IP55 (Specified by I.E.C.)

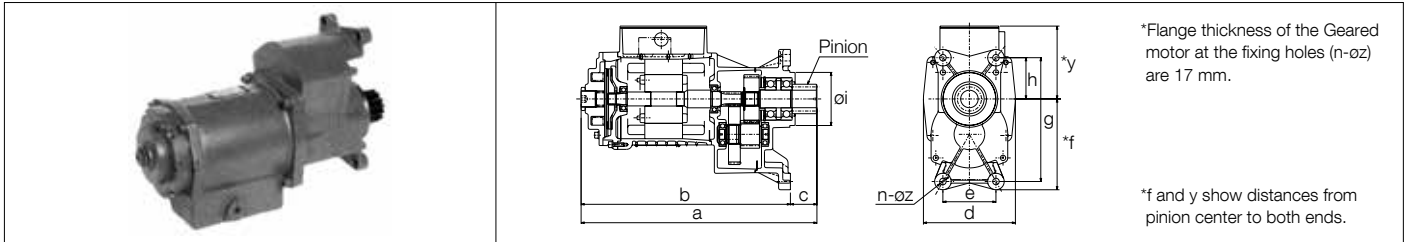

Type	Motor output (kW)	Pole	Power source	Dimensions (mm)											Mass (Net Weight) (kg)								
				a		b	c		d	e	f	y	g	h		oi	n	oz					
Overhead	Low-head	Overhead	Low-head																				
G1M□075L-□	0.75	4	H : 220 V 60 Hz M : 220/440 V 60 Hz or 230/460 V 60 Hz S : 220/380 V 50 Hz X : 380,415 V 50 Hz	400	393	355	45	38	156	90	154	122.6	210	70	90 ⁰ _{-0.054}		11		26				
G1M□075S-□																							
G1M□075H-□																							
G1M□075SD-□	0.75/0.19	2/8	For CSA V : 220/440 V 60 Hz For CSA K : 575 V 60 Hz	415	370															27			
				433		426														388			
G1MO150T-□	1.5	4	H : 220 V 60 Hz M : 220/440 V 60 Hz or 230/460 V 60 Hz S : 220/380 V 50 Hz X : 380,415 V 50 Hz	433	426	388											4			36			
G1MO150L-□																						45	
G1MO150S-□																							45
G1MO150H-□																							45
G1MO150SD-□				1.5/0.38	2/8	For CSA K : 575 V 60 Hz V : 220/440 V 60 Hz	484		419	65		190	110	177	132.6	242	80	115 ⁰ _{-0.054}			13		46

- Brake: DC Disk Brake.
- Brake Torque: From 0 to 50% of motor rated Torque.
- Dust and water protection: IP55 (Specified by I.E.C.)

How to read types and codes

Type **Types of end carriages** **Code** **Code of end carriages** **Motor output**

O: Overhead L: Low-head J: Overhead C: Low-head

G1M□025□-□ **G1□□025□**

Types of geared motor

Motor output
 025: 0.25 kW 070: 0.75 kW
 040: 0.45 kW 150: 1.5 kW

Speed (50-60Hz)
 L, S, H and T are common to both "Type" and "Code".
 L: 10/12 m/mim (Low speed)
 S: 20/24 m/mim (Standard speed)
 H: 30/36 m/mim (High speed)
 (T: 30/36 m/mim)
 SD (for "Type"), B (for "Code"): 20/5 24/6 m/mim (Dual speed)

Power source
 H: 220 V 60 Hz (for CSA)
 S: 220/380 V 50 Hz K: 575 V 60 Hz
 M: 220/440 230/460 V 60 Hz V: 220/440 V 60 Hz
 X: 380-415 V 50 Hz

■ Specifications of Geared Motor Pinions

Type	Motor output (kW)	*Traveling speed (m/min)		*Motor revolutions (r.p.m)		Pinion					
						*Revolutions (r.p.m)		Tooth surface strength (kg)			
								Overhead		Low-head	
50 Hz	60 Hz	50 Hz	60 Hz	50 Hz	60 Hz	50 Hz	60 Hz	50 Hz	60 Hz		
G1M□025L-□	0.25	10	12	1410	1650	155	181	158	134	105	90
G1M□025S-□		20	24			314	367	78	66	52	44
G1M□025H-□	0.4	30	36	1430	1700	463	541	53	45	35	30
G1M□040T-□		5	6			469	557	83	70	59	47
G1M□025SD-□	0.063	5	6	730	870	80	91	77	67	51	45
G1M□040L-□	0.4	10	12	1430	1700	132	156	247	208	165	139
		20	24			255	302	128	107	85	72
G1M□040S-□	0.75	30	36	1415	1670	382	453	86	72	57	48
G1M□040H-□		5	6			378	445	162	137	108	92
G1M□075T-□	0.1	5	6	730	860	68	79	121	103	81	68
G1M□040SD-□	0.4	20	24	2890	3420	266	314	123	103	82	69
G1M□075L-□	0.75	10	12	1415	1670	77	91	527	446	323	255
G1M□075S-□		20	24			146	173	278	235	158	134
G1M□075H-□	1.5	30	36	1440	1700	224	253	182	160	104	92
G1M□105T-□		5	6			218	256	372	317	—	—
G1M□075SD-□	0.19	5	6	720	860	39	47	263	219	161	125
G1M0150L-□	1.5	10	12	1440	1700	65	77	1022	862	—	—
		20	24			127	149	522	446	—	—
G1M0150H-□	0.38	30	36	710	840	192	227	345	292	—	—
G1M0150SD-□		5	6			32	38	526	443	—	—
G1M0150S-□	1.5	20	24	2920	3480	131	157	507	423	—	—
		507	423			—	—				

*Figures in the table are approximate values.

■ Details of Pinions

Type	Motor output (kW)	Pole	Pinion (mm)				
			Module	Number of teeth	x	Outside diameter	
G1M0025□-□	0.25	4	2.5	8	0.452	27.1 ⁰ _{-0.1}	
G1M0025□-□	0.25/0.063	2/8		12	0.294	36.5 ⁰ _{-0.2}	
G1M0040T-□	0.4	4	3	8	0.452	27.1 ⁰ _{-0.1}	
G1ML040T-□				12	0.294	36.5 ⁰ _{-0.2}	
G1M0040□-□	0.4	4	3	8	0.460	32.8 ⁰ _{-0.2}	
G1ML040□-□				12	0.294	43.8 ⁰ _{-0.2}	
G1M0075T-□	0.75	4	3	8	0.460	32.8 ⁰ _{-0.2}	
G1ML075T-□				12	0.294	43.8 ⁰ _{-0.2}	
G1M0075□-□	0.75	4	3	4.5	8	0.550	50 ⁰ _{-0.2}
G1ML075□-□				2.5	21	-0.04	68.8 ⁰ _{-0.2}
G1M0150T-□	1.5	4	4.5	8	0.550	50 ⁰ _{-0.2}	
G1M0150□-□	1.5	4	5.5	8	0.550	61 ⁰ _{-0.2}	

- Heat treatment: Case hardened HRC: 57 to 63.
- X: Addendum modification coefficient.

■ Brake Torque Adjustment

Torque can be adjusted within a range of 30 to 80% for a 0.25 kW motor and 0 to 50% for motors exceeding 0.4 kW of the rated torque by loosening the lock nut and setting the height of the adjusting bolt. Be sure to tighten the nut and fix the bolt after adjustment. Adjustment is the set-less type.

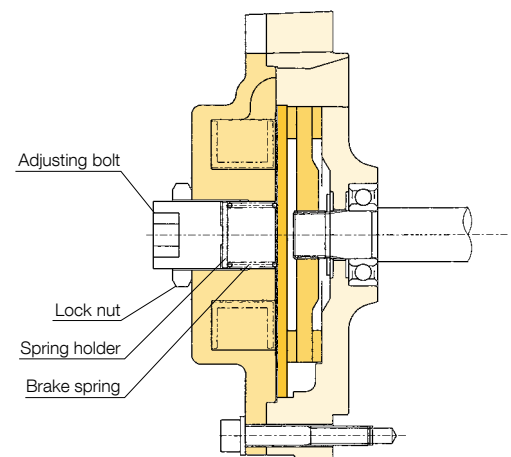

KITO CRANES can be fitted with peripheral equipment for greater durability, higher performance and greater

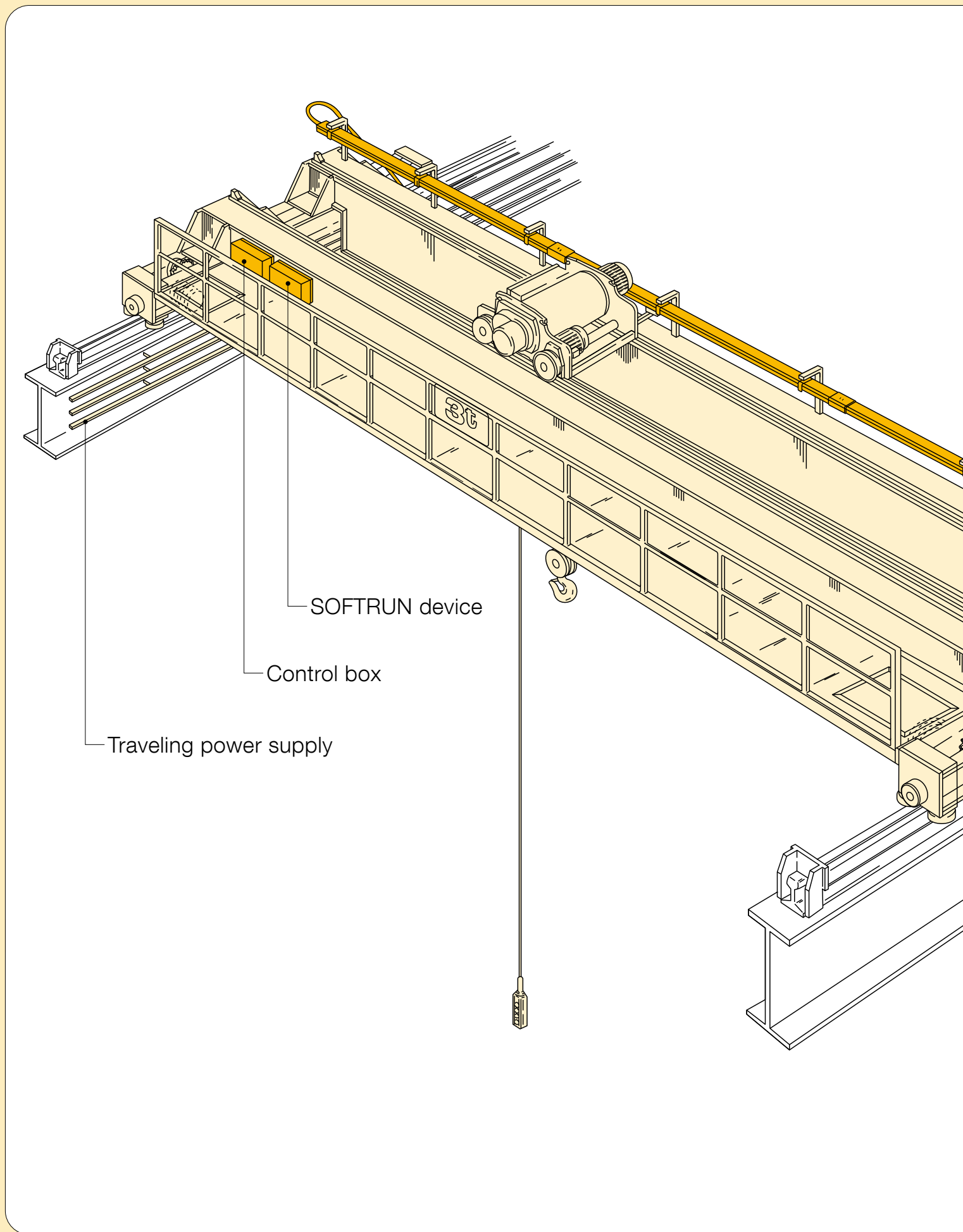

operational efficiency.

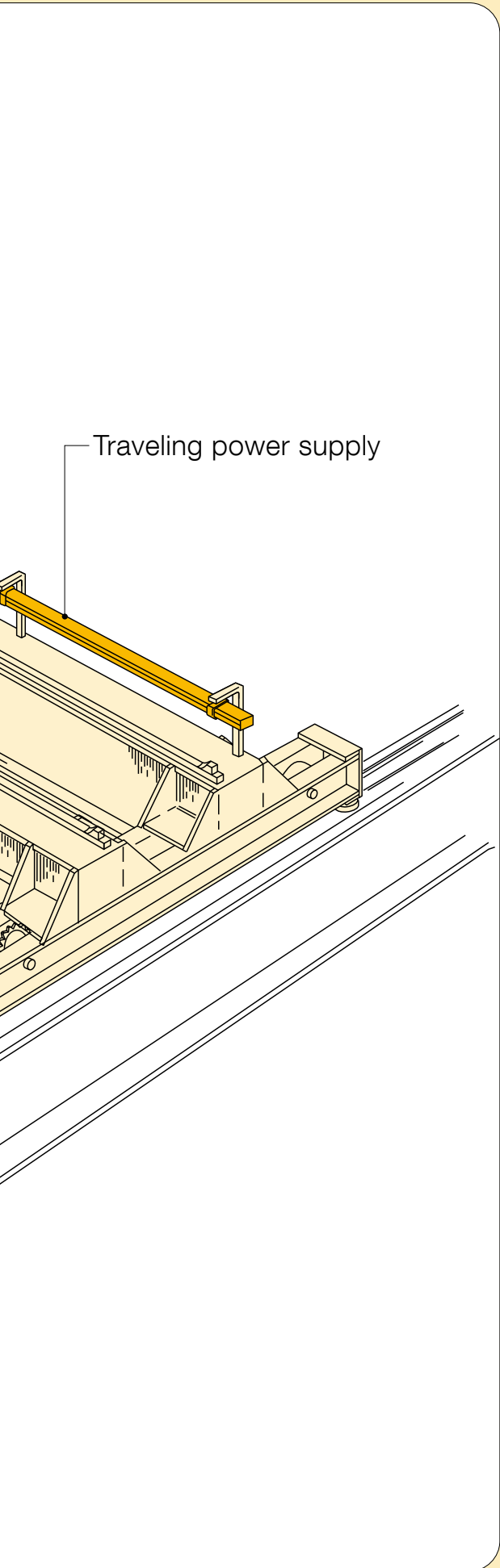

Control Boxes

Dual speed

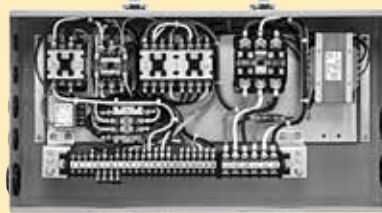

For an electric chain hoist with an emergency stop device.

Single speed

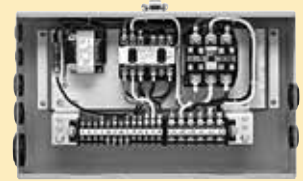

For a rope hoist with an emergency stop device.

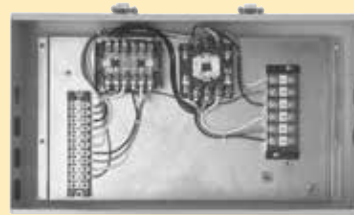

For a rope hoist with an emergency stop device.



Emergency Stop Device



For an electric chain hoist



For a rope hoist (option)

SOFTRUN Device (option)

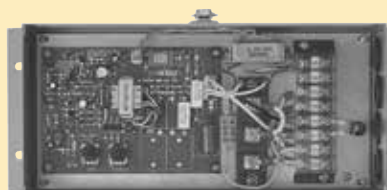

CONTROL BOXES

For electric chain hoist (ER2M)

This control box includes a built-in electromagnetic contactor and a transformer with control voltage of 24V. Other control voltages are available as an option. All models are equipped with an emergency stop device as standard.

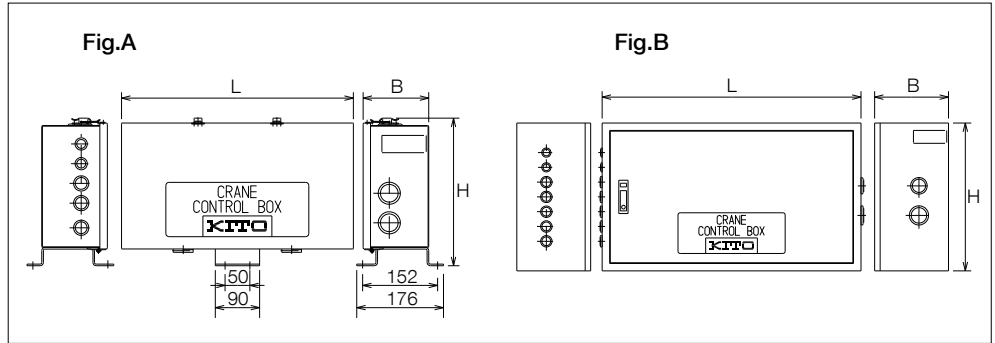
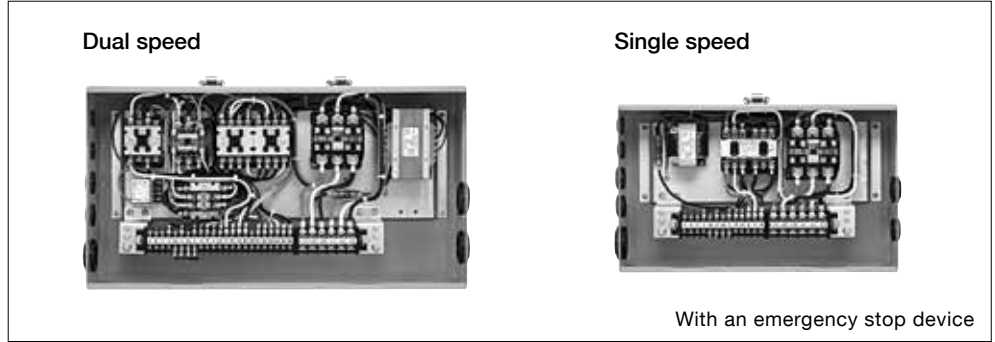

Type	Geared motor output	Power supply		Pendant control voltage	Rated current		Outline	Dimensions (mm)			Mass (Netweight) (kg)
		Rated voltage	Working voltage range		Control box	Traveling		H	B	L	
Single speed	~0.75kWx2	200V 50Hz	±10%	24~26.4V	40A	11A	Fig.A	256	128	348	7
		200~220V 60Hz									
		380~415V 50Hz									
		440V 60Hz									
	~1.5kWx2	220~230V 50/60Hz	±10%	24~26.4V	70A	16A	Fig.A	300	133	390	9
		380~400V 50/60Hz									
		200V 50Hz									
		200~220V 60Hz									
~1.5kWx4	380~415V 50Hz	±10%	24~26.4V	40A	7.5A	Fig.A	300	133	440	9	
	440V 60Hz										
	220~230V 50/60Hz										
	380~400V 50/60Hz										
Dual speed	~0.75kWx2	200V 50Hz	±10%	24~26.4V	40A	11A	Fig.A	300	133	470	11
		200~220V 60Hz									
		380~415V 50Hz									
		440V 60Hz									
	~1.5kWx2	220~230V 50/60Hz	±10%	24~26.4V	70A	16A	Fig.A	300	133	470	11
		380~400V 50/60Hz									
		200V 50Hz									
		200~220V 60Hz									
~1.5kWx4	380~415V 50Hz	±10%	24~26.4V	40A	17A	Fig.B	400	200	700	27	
	440V 60Hz										
	220~230V 50/60Hz										
	380~400V 50/60Hz										

- Available on your request.
- Environment: Ambient temperature: -20 to 40°C (No freezing) Installation site: Indoor, free of dust and corrosive gases.
- Protection class : IP20
- Color: Munsell 6YR6/14

For wire rope hoist

This control box contains a built-in electromagnetic contactor for controlling travel. Two series (with and without emergency stop device) are available with a built-in electromagnetic contactor.

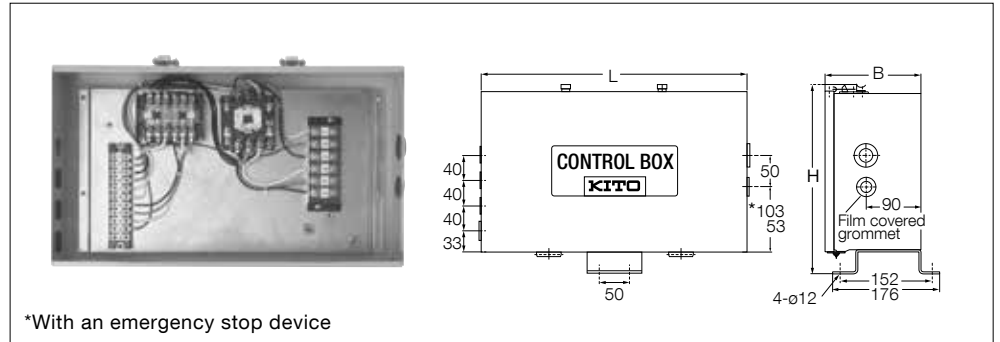

Type	Emergency stop device	Geared motor output	Power supply		Pendant control voltage	Rated current		Dimensions (mm)			Mass (Netweight) (kg)			
			Rated voltage	Working voltage range		Control box	Traveling	H	B	L				
Single speed	Without	0.25 kWx2	220 V 60 Hz	±10%	220 V	50 A	11 A	256	128	348	7			
			380,415 V 50 Hz		48 V		7 A							
	With	0.4 kWx2	220 V 60 Hz		220 V		11 A	300	158	440	8			
			380,415 V 50 Hz		48 V		7 A							
	Without	0.75 kWx2	0.75 kWx2		220 V 60 Hz	±10%	220 V	70 A	11 A	256	128	348	7	
					380,415 V 50 Hz		48 V		7 A					
					With		0.75 kWx2	220 V 60 Hz	220 V	11 A	300	158	440	9
								380,415 V 50 Hz	48 V	7 A				
Without	1.5 kWx2	1.5 kWx2	220 V 60 Hz	±10%	220 V	100 A	20 A	300	133	390	8			
			380,415 V 50 Hz		48 V		10 A							
*Dual speed	Without	0.25 kWx2	220 V 60 Hz	±10%	220 V	-	-	-	-	-	-			
			380,415 V 50 Hz		48 V									
	With	0.4 kWx2	22 V 60 Hz		220 V									
			380,415 V 50 Hz		48 V									
	Without	0.75 kWx2	0.75 kWx2		220 V 60 Hz	±10%	220 V	-	-	-	-	-		
					380,415 V 50 Hz		48 V							
					With		0.75 kWx2	220 V 60 Hz	220 V					
								380,415 V 50 Hz	48 V					
Without	1.5 kWx2	1.5 kWx2	220 V 60 Hz	±10%	220 V	-	-	-	-	-				
			380,415 V 50 Hz		48 V									

*Available on request.

- Environment: Ambient temperature: -10 to 40 °C (No freezing) Installation site: Indoor, free of dust and corrosive gases.
- Dust and water protection: IP20 (Specified by I.E.C.)
- Color: Munsell 6YR6/14

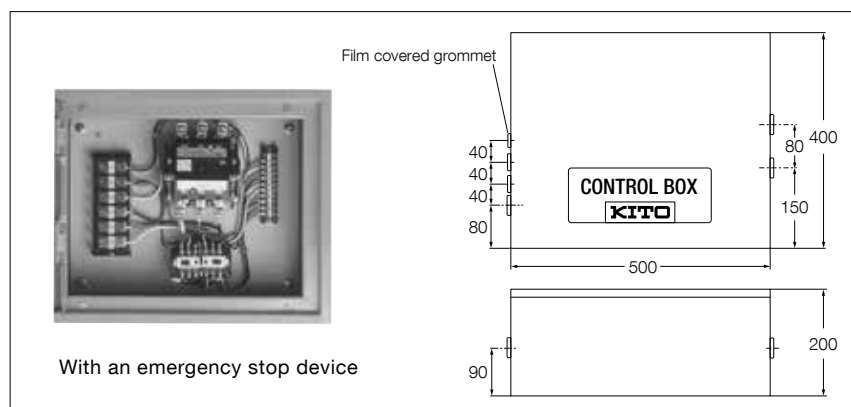

Type	Emergency stop device	Geared motor output	Power supply		Pendant control voltage	Rated current		Mass (Netweight) (kg)
			Rated voltage	Working voltage range		Control box	Traveling	
Single speed	With	1.5 kWx2	220 V 60 Hz	±10%	220 V	100 A	20 A	17
			380,415 V 50 Hz		48 V		10 A	

- Environment: Ambient temperature: -10 to 40 °C (No freezing) Installation site: Indoor, free of dust and corrosive gases.
- Dust and water protection: IP20 (Specified by I.E.C.)
- Color: Munsell 6YR6/14

POWER SUPPLY CABLES AND ACCESSORIES

Power supply cable

Wiresx cross-sectional area	4C x 2□	4C x 3.5□	6C x 2□	8C x 2□	4C x 5.5□	4C x 8□	4C x 14□	4C x 22□	4C x 30□
Cable diameter	φ12.3	φ14.2	φ14.5	φ16.8	φ17.5	φ19.5	φ24	φ30	φ36
Part No.	CTC4C x 2	CTC4C x 3.5	CTC6C x 2	CTC8C x 2	CTC4C x 5.5	CTC4C x 8	CTC4C x 14	CTC4C x 22	CTC4C x 30
Type	Vinyl power supply cable (VCT)					Rubber power supply cable (2CT)			

Junction cable for electric chain hoist (ER2M) and rope hoist

Junction cable connecting the crane control box to the electric chain hoist. It is used for the power supply and operation circuits.

Wiresx cross-sectional area	7C composite cable (4C x 3.5□ + 3C x 0.75□)	8C composite cable (4C x 3.5□ + 4C x 0.75□)	9C composite cable (4C x 3.5□ + 5C x 0.75□)
Cable diameter	φ17.9	φ19.4	φ22.3
Part No.	CTC4C + 3C	CTC4C + 4C	CTC4C + 5C
Type	Vinyl power supply cable (VCT)		

Wire guide L

This guide is used to power the supply cable system (for low-head end carriage).

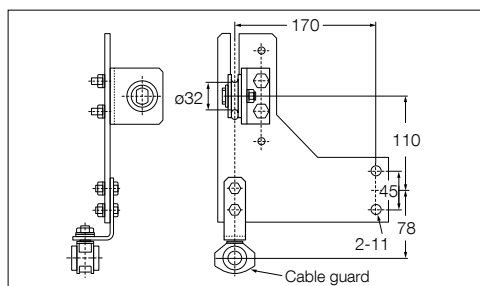

Type	Cable size		Cable guard
	Outer diameter	Wiresx cross-sectional area	
WGL16	φ14.2	4C x 3.5□	CG16
WGL19	*φ17.0 to φ19.0	4C x 5.5□ 4C x 8□	CG19

* Option

Wire guide O

This guide is used to power the supply cable system (for both overhead and low-head types).

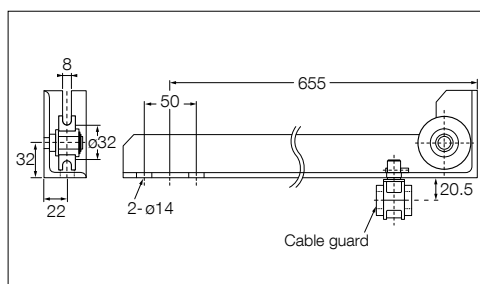

Type	Cable size		Cable guard
	Outer diameter	Wiresx cross-sectional area	
WGO16	φ14.2	4C x 3.5□	CG16
WGO19	*φ17.0 to φ19.5	4C x 5.5□ 4C x 8□	CG19

* Option

Wire bolt assembly

This bolt is used to fix messenger wires.

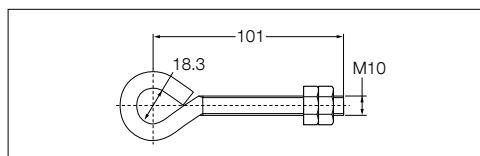

Type	With φ4 to φ6 wire clip
WB	

Allowable length (m) of power supply cable (200V)

IA	Cross-Section area (mm²)						
	2□	3.5□	5.5□	8□	14□	22□	30□
10	25	45	71	103			
15	17	30	47	69	121		
20	12	22	35	51	90		
25		18	28	41	72	114	
30			23	34	60	95	
35			20	29	51	81	111
40				25	45	71	97
45				23	40	63	86
50					36	57	77
60					30	47	64
70						40	55
80						35	48
90							43
100							38

How to identify allowable power supply cable

- Internal wiring specification JEAC8001-1995 120-1 Voltage drop

The voltage drop in low voltage lines is, as a rule, to be kept within 2% of the standard voltage of the trunk line and the branch circuit.

$$\text{Allowable length (m)} = \frac{1000}{30.8} \times \frac{\text{Cross-sectional area of single wire (mm}^2\text{)} \times \text{rated voltage} \times 0.02}{I A}$$

I A : Electric chain hoist or rope hoist
Rated current + Rated current of travel motor x 2

CABLE HANGERS

Angled hanger

This hanger uses an angle steel to hang power supply cables. The THLP type is used to hang push-button cord.

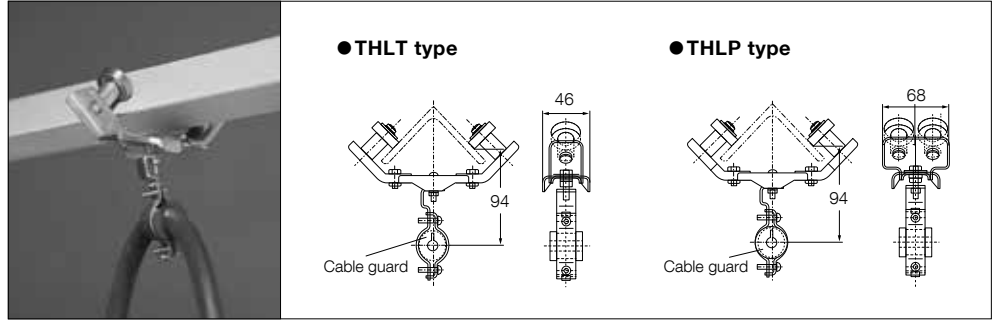

Type	Angle steel width	Cable size
THLT26S-75	L-50x50x6 to L-75x75x9	ø10 to ø26
THLP26S-75	L-75x75x9	ø10 to ø26

T-type hanger for wire rope hoists

This hanger is used to hang power supply cables and is suited for all sizes of cable and rails.

- Suited for hanging dynamic and operation cables for rope hoists.

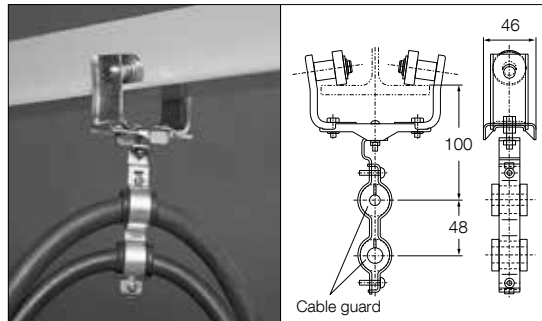

Type	Rail width	Cable size	
		Upper	Lower
THI19W-100V	75 to 150	ø10 to ø22	
THI19W-175V	175	ø10 to ø22	
THI26W-100V	75 to 150	ø22.1 to ø26	ø10 to ø22
THI26W-175V	175	ø22.1 to ø26	ø10 to ø22

T-type hanger for electric chain hoist (ER2M)

This hanger is used to hang power supply cables. It is applicable for all sizes of cable and rail widths, and is suited for compound cables.

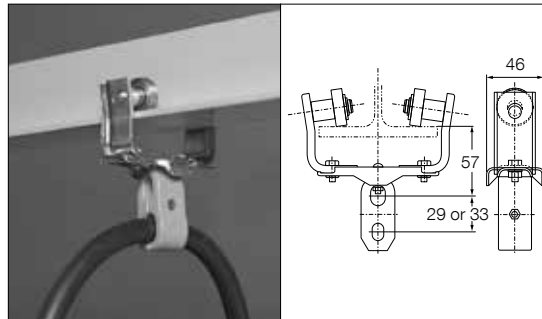

Type	Rail width	Cable size
TTH19S-100V	75 to 150 mm	ø16.8 or ø19.4 to ø19.5
TTH19S-175V	175 mm	ø16.8 or ø19.4 to ø19.5
TTH21S-100V	75 to 150 mm	ø16.8 or ø22.3
TTH21S-175V	175 mm	ø16.8 or ø22.3

Cable hanger

This hanger is used to hang power supply cables with messenger wires.

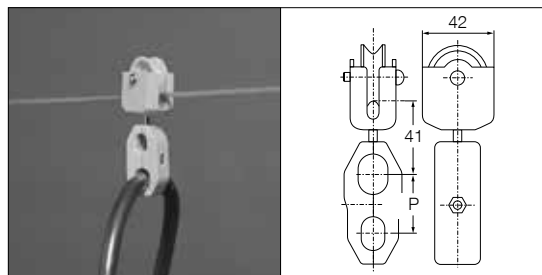

Type	Messenger wire	Cable size	P
CH19S	ø4 to ø6	ø16.8 or ø19.4 to ø19.5	29
CH21S	ø6	ø16.8 or ø22.3	33

Cable guard

This guard is used to protect cables strung from T-type and angled hangers.

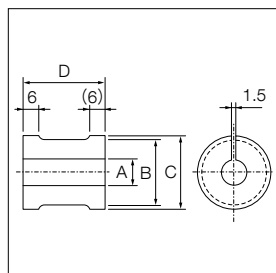

Type	Cable size	øA	øB	øC	D
CG13	ø10 to ø13	10	25		
CG16	ø13.1 to ø16	13			
CG19	ø16.1 to ø19	16	26	28	32
CG22	ø19.1 to ø22	19			
CG26	ø22.1 to ø26	22	34	37	

CRANE GIRDER ALLOWABLE SPAN

Single Rail (JIS)

Girder section	Dimensions A x B x t ₁ x t ₂	(kg/m)	Allowable span (m)								
			500 kg	1.0 t	1.5 t	2.0 t	2.5 t	3.0 t	5.0 t	7.5 t	10 t
 I-beam	I-200 x 100 x 7 x 10	26	6.0	4.6							
			6.0	4.6							
	I-250 x 125 x 7.5 x 12.5	38.3	8.6	6.7	5.5	4.5	4.0				
			8.3	6.1							
	I-250 x 125 x 10 x 19	55.5	11.2	8.2	6.9	6.0	5.4	4.9			
			11.2	8.2	6.9	6.0	5.4	4.9			
	I-300 x 150 x 8 x 13	48.3	10.2	9.0	6.8	6.1	5.6	4.9			
			10.0	7.6							
	I-300 x 150 x 10 x 18.5	65.5	11.6(11.2)	10.2	8.5	7.7	6.8	6.2	3.8		
			11.6(11.2)	10.2	8.5	7.4	6.7	6.4	4.3		
	I-300 x 150 x 11.5 x 22	76.8	11.6(11.2)	11.2	9.4	8.2	7.5	6.9	5.4		
			11.6(11.2)	11.2	9.4	8.2	7.5	6.9	5.0		
	I-350 x 150 x 9 x 15	58.5	11.2	9.4	7.8	6.9	6.4	6.0	3.6		
			11.0	9.0	7.7						
	I-350 x 150 x 12 x 24	87.2	11.6(11.2)	11.6(11.2)	11.3(11.2)	9.9	9.0	8.3	6.6	4.5	
			11.6(11.2)	11.6(11.2)	11.3(11.2)	9.9	9.0	8.3	6.1	4.2	3.1
I-400 x 150 x 10 x 18	72	11.6(11.2)	11.0	9.3	8.3	7.6	7.2	5.6			
		11.6(11.2)	10.6	8.7	8.1	7.5	7.1	5.1			
I-400 x 150 x 12.5 x 25	95.8	11.6(11.2)	11.6(11.2)	11.6(11.2)	11.3(11.2)	10.3	9.2	6.8	5.2	3.9	
			11.6(11.2)	11.6(11.2)	11.2	9.4	8.7	6.6	4.8	3.6	
I-450 x 175 x 11 x 20	91.7	11.6(11.2)	11.6(11.2)	11.6(11.2)	10.5	9.6	8.8	6.8	5.6		
			11.6(11.2)	11.0	10.7	9.9	9.3	6.8			
I-450 x 175 x 13 x 26	115	11.6(11.2)	11.6(11.2)	11.6(11.2)	11.6(11.2)	11.6(11.2)	11.1	8.5	6.8	5.4	
					11.6(11.2)	11.4(11.2)	10.5	8.1	6.5	4.8	

: For kito electric hoist.

: For kito wire rope hoist.

- The above data is calculated according to the crane standard in Japan: Deflection=Within 1/1000 x span. Allowable bending stress=Within 1390 kg/cm²
- A stop drawing for the girder available on request.
- The figures in parentheses are data for Low-head cranes.

PERIPHERAL EQUIPMENT COVERAGE

■ Table of Control Box for Electric Chain Hoist (Single speed)

Type	W.L.L. (t)	Span (m)									
		3	6	9	12	15	18	21	24	27	
Motorized	Overhead	1	SBM015S,SN								
		2									
		3									
		5									
	Low-head	7.5	SBM015S,SN (SBM030S,SN)								
		10									
		1	SBM015S,SN								
		2									
Urethane Wheel Type	Overhead	3									
		5									
		7.5	SBM015S,SN (SBM030S,SN)								
		10	SBM030S,SN								
	Low-head	10					SBM030S,SN (*SBM060S,*SN)				
		1	SBM015S,SN								
		2									
		3									
Double Girder	Overhead	3	SBM015S,SN								
		5									
		7.5	SBM015S,SN (SBM030S,SN)								
		10							SBM030S,SN		
		15	SBM030S,SN								
		20	SBM030S,SN (*SBM060S,*SN)								
	Urethane Wheel Type	3	SBM015S,SN (SBM030S,SN)								
		5	SBM030S,SN								
		7.5									
		10	*SBM060S,*SN								
		15									
		20	*SBM060S,*SN (*SBM120S,*SN)								

•S: Without emergency stop device. SN: With emergency stop device.

Types in parentheses show high speed type.

*Available on request.

■ Table of Control Box for Electric Chain Hoist (Dual speed)

Type	W.L.L. (t)	Span (m)									
		3	6	9	12	15	18	21	24	27	
Motorized	Overhead	1	SBM015SD,SDN								
		2									
		3									
		5									
		7.5									
	10										
	Low-head	1									
		2									
		3									
5											
Urethane Wheel Type	Overhead	1	SBM015SD,SDN								
		2									
		3									
		5									
		7.5	SBM030SD,*SDN								
		10									
	Low-head	1	SBM015SD,SDN								
		2									
Double Girder	Overhead	3	SBM015SD,SDN								
		5									
		7.5									
		10									
		15	SBM030SD,*SDN								
		20									
	Urethane Wheel Type	3	SBM015SD,SDN								
		5	SBM030SD,*SDN								
		7.5									
		10	*SBM060SD,*SDN								
		15									
		20									

•SD: Without emergency stop device. SDN: With emergency stop device.

*Available on request.

■ Table of Control Box for Wire Rope Hoist (Single speed)

Type	W.L.L. (t)	Span (m)									
		3	6	9	12	15	18	21	24	27	
Motorized	Overhead	1	SBH008S,\$N								
		2									
		3									
		5				SBH008S,\$N (SBH015S,\$N)					
		7.5	SBH015S,\$N (SBH030S,*\$N)								
		10									
	Low-head	1	SBH008S,\$N								
		2									
		3									
		5	SBH008S,\$N (SBH015S,\$N)		SBH015S,\$N						
Urethane Wheel Type	Overhead	1	SBH008S,\$N								
		2									
		3	SBH015S,\$N								
		5	SBH015S,\$N (SBH030S,*\$N)								
		7.5	SBH030S,*\$N								
		10				SBH030S,*\$N (*\$SBH060S,*\$N)					
	Low-head	1	SBH008S,\$N								
		2	SBH008S,\$N (SBH015S,\$N)								
Double Girder	Overhead	3	SBH008S,\$N				SBH008S,\$N (SBH015S,\$N)				
		5	SBH008S,\$N (SBH015S,\$N)								
		7.5	SBH015S,\$N (SBH030S,*\$N)								
		10						SBH030S,*\$N			
		15	SBH030S,*\$N								
		20	SBH030S,*\$N (*\$SBH060S,*\$N)								
	Urethane Wheel Type	3	SBH015S,\$N (SBH030S,*\$N)								
		5	SBH030S,*\$N								
		7.5									
		10	*\$SBH060S,*\$N								
		15									
		20	*\$SBH060S,*\$N (*\$SBH120S,*\$N)								

•S: Without emergency stop device. \$N: With emergency stop device.

Types in parentheses show high speed type.

*Available on request.

■ Table of Control Box for Electric Chain Hoist (Dual speed)

Type	W.L.L. (t)	Span (m)									
		3	6	9	12	15	18	21	24	27	
Motorized	Overhead	1	SR150S								
		2									
		3									
		5									
		7.5	SR150S (SR300S)								
	10										
	Low-head	1	SR150S								
		2									
		3									
		5									
Urethane Wheel Type	Overhead	1	SR150S								
		2									
		3									
		5	SR150S (SR300S)								
		7.5	SR300S								
		10					SR300S (SR300SX2)				
	Low-head	1	SR150S								
		2									
Double Girder	Overhead	3	SR150S								
		5									
		7.5	SR150S (SR300S)								
		10							SR300S		
		15	SR300S								
		20	SR300S (SR300SX2)								
	Urethane Wheel Type	3	SR150S (SR300S)								
		5	SR300S								
		7.5									
		10	SR300SX2								
		15									
		20	SR300SX2 (SR300SX4)								

•Types in parentheses show high speed type.

KITO



SHINJUKU NS Bldg. 9F,
2-4-1 Nishi-Shinjuku, Shinjuku-ku, Tokyo 163-0809 JAPAN
TEL: +81-3-5908-0180 FAX: +81-3-5908-0189
E-mail: overseas@kito.co.jp
www.kito.co.jp
KITO Global Website: kito.com

International Sales Subsidiaries

U.S.A.

HARRINGTON HOISTS, INC.

401 West End Avenue, Manheim, PA 17545, U.S.A.
TEL: +1-717-665-2000 FAX: +1-717-665-2861
www.harringtonhoists.com

CANADA

KITO CANADA INC.

309-3815 1st. Avenue, Burnaby, BC. V5C 3V6, CANADA
TEL: +1-604-291-9955 FAX: +1-604-294-8855
E-mail: info@kito.ca
www.kito.ca

BRAZIL

KITO DO BRASIL COMERCIO DE TALHAS E GUINDASTES LTDA

Rua Paraíso 45, Conj32, Paraíso São Paulo, SP, CEP 04103-000, BRAZIL
TEL: +55-11-3253-1000 FAX: +55-11-3253-1008

GERMANY

KITO EUROPE GmbH

Heerdter Lohweg 93, D-40549 Düsseldorf, GERMANY
TEL: +49-(0)211-528009-00 FAX: +49-(0)211-528009-59
E-mail: info@kito.net
www.kito.net

CHINA

JIANGYIN KITO CRANE CO., LTD.

18 Cheng Jiang East Road, Jiang Yin, Jiang Su 214429, CHINA
TEL: +86-510-86199666 FAX: +86-510-86196633
www.kaicheng.com

SHANGHAI KITO TRADING CO., LTD.

Room 11J, Zao-Fong Universe Building, No1800 ZhongShan West Road Shanghai 200235, CHINA
TEL: +86-21-54488935 FAX: +86-21-54488937
www.kito.com.cn

KOREA

KITO KOREA CO., LTD.

463-400, Pangyo 7 Venture Valley 9th F1., 3Dong, 625
Sampyeong-Dong, Bundang-Gu, Seongnam-Si Gyeonggi-Do, KOREA
TEL: +82-31-600-7450 FAX: +82-31-600-7469
www.kito.kr

THAILAND

SIAM KITO CO., LTD.

700/243 M.1, Amatanakorn Industrial Estate Phase 2,
Bangna-Trad KM.57, T.Bankao, A.Panthong, Chonburi 20160, THAILAND
TEL: +66-3846-8205 FAX: +66-3846-8195
www.siamkito.co.th

INDONESIA

PT. KITO INDONESIA

Wisma Keiai 5F, Jl. Jend. Sudirman Kav.3-4, Jakarta 10220, INDONESIA
TEL: +62-21-572-4261 FAX: +62-21-572-4267
E-mail: sales@id.kito.com

INDIA

Armsel MHE Pvt. Ltd.

No-10/4, 5F, Mitra Towers, Kasturba Road, Bangalore-560001, Karnataka, INDIA
TEL: +91-80-49010500 FAX: +91-80-49010555
www.armsel.com

Features and performances of all the products described in this catalogue are designed for their own intended purposes.

KITO will not be held liable for any malfunction, lack of performance or accident if the product is being used in conjunction with any other equipment.

If the product is to be used for unintended purposes, please confirm with your dealer in advance.

All rights reserved.

All specifications herein are subject to change without notice.

Distributed by:



This printed paper is made from the trees
harvested in well-managed forests.